

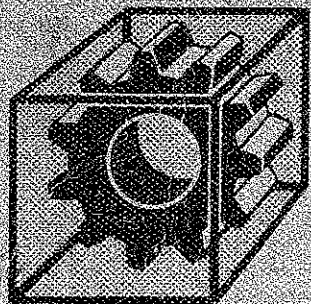

*Diesel Indenor*

**PEUGEOT**



**P.R. 915**

**X4M88S**

**X4M90S**

**X4M90AL/A**

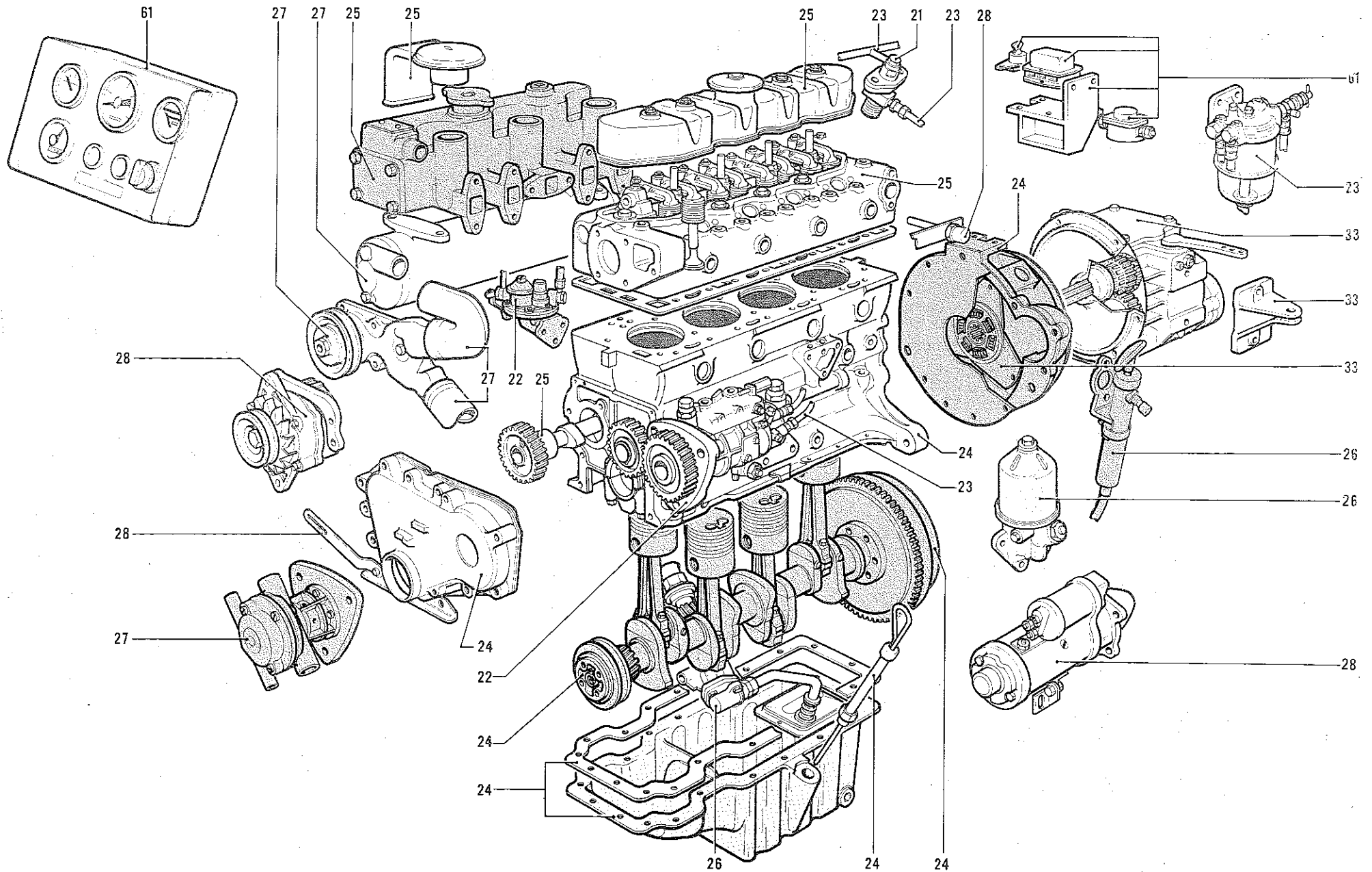



01-20 A



02-01 A

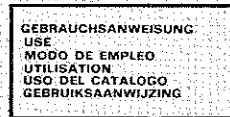

03-00

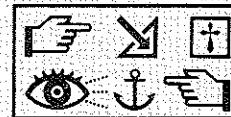

05-01 A

20  
21

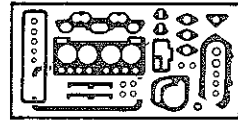

20-05 A

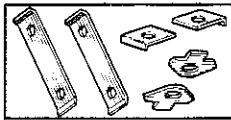

20-10 A

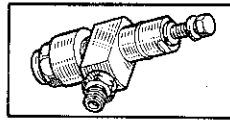

21-05 A

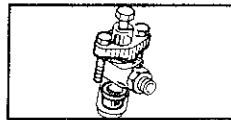

21-40

20  
21

22

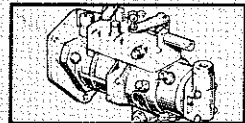

22-01 A 22-02 A 22-03 A  
22-10 A 22-11 A 22-12 A

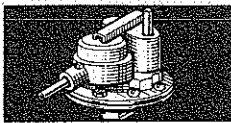

22-30 A

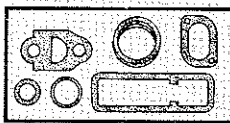

22-35 A

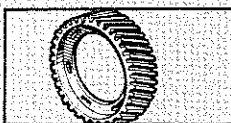

22-40 A

22

23

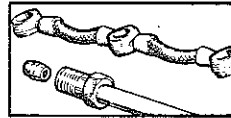

23-01 A

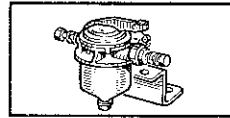

23-15 A

23

24

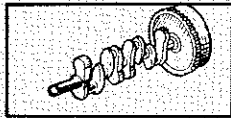

24-01 A

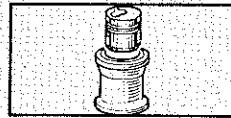

24-05 A

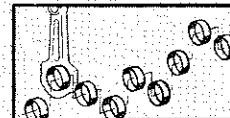

24-10 A

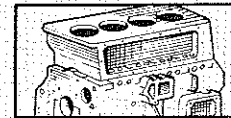

24-15 A

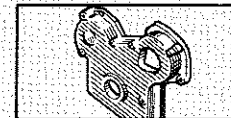

24-20 A

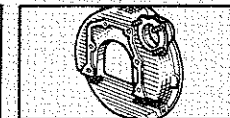

24-25 A

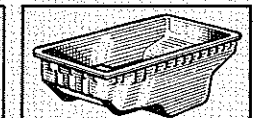

24-30 A

24

25

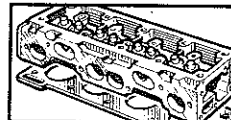

25-01 A



25-10 A

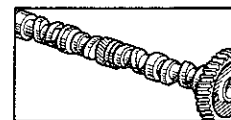

25-20 A

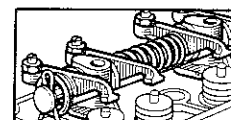

25-25 A

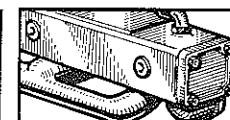

25-30 A

25

26

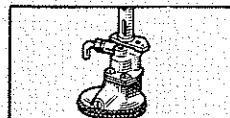

26-01 A



26-05 A

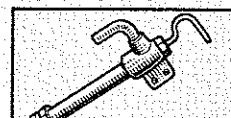

26-15 A

26

27

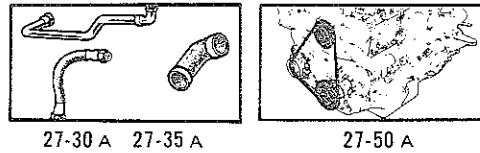
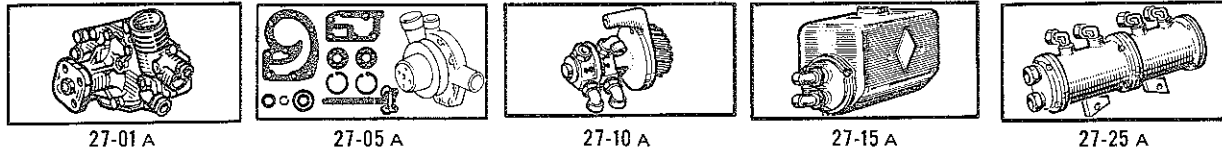

27

28

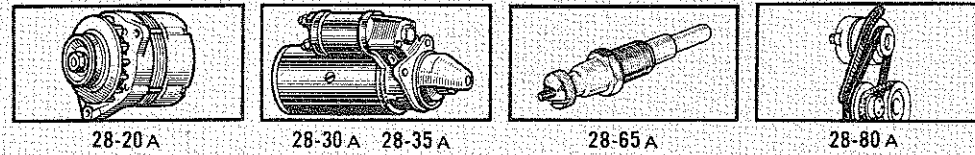

28

33

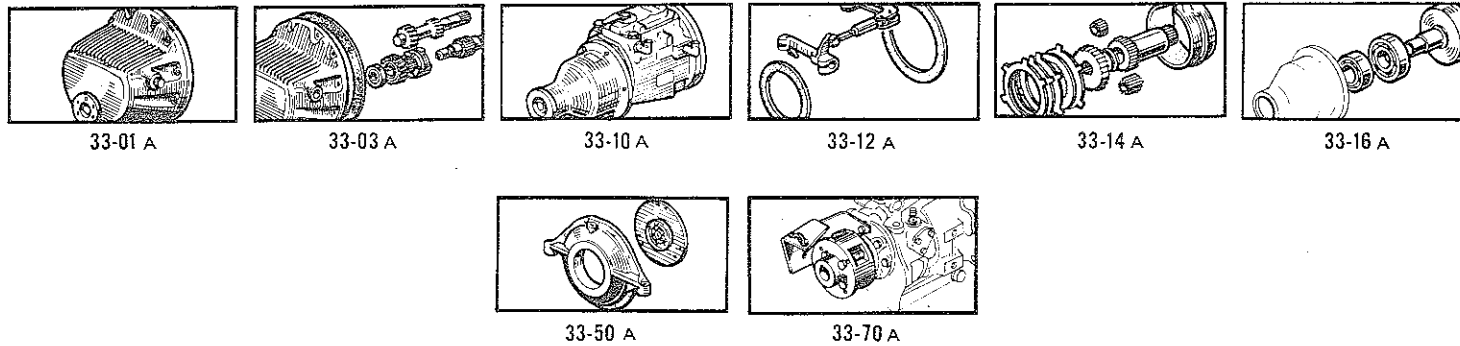

33

61  
62

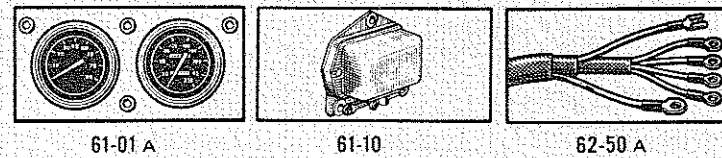

61  
62

120  
130

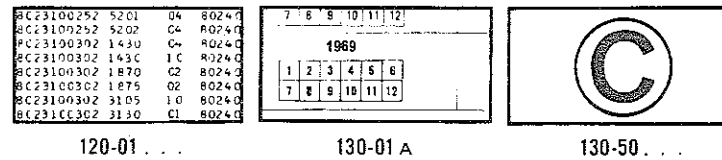

120-01 . . .

130-01 A

130-50 . . .

120  
130

SOCIÉTÉ COMMERCIALE DE MOTEURS - C.L.M  
49, Rue Noël Pons - B.P. 35 - 92-NANTERRE  
Tél. : 781.40.11  
Telex. 62162 Cogemot Nanterre

**X4M88S**

**X4M90S**

**X4M90AL/A**

**01.20**  
A. P.R. 915

DIESELTECHNIEK NEDERLAND N.V  
Zinkstraat 7 - RIDDERKERK - HOLLANDE  
Tél. : (018 96) 3277  
Telex. 23697 Paulimex Rdam

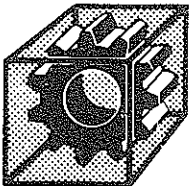
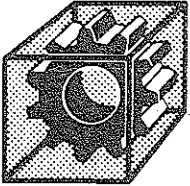
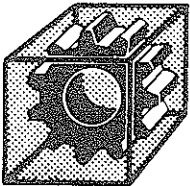
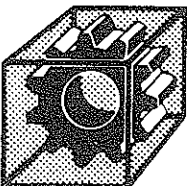
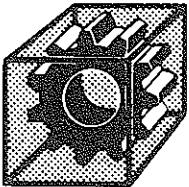
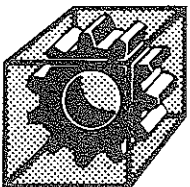
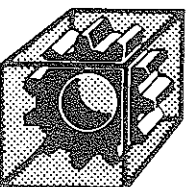
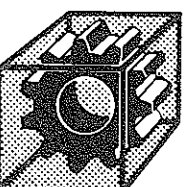
<p>FRANÇAIS</p> <p>Catalogue de pièces de rechange</p>  <p><b>P.R. 915</b></p>	<p>DANSK</p> <p>Reservedelskatalog</p>  <p><b>P.R. 915</b></p>	<p>DEUTSCH</p> <p>Ersatzteilkatalog</p>  <p><b>P.R. 915</b></p>	<p>ENGLISH</p> <p>Spare parts catalogue</p>  <p><b>P.R. 915</b></p>
<p>ESPAÑOL</p> <p>Catálogo de piezas de repuesto</p>  <p><b>P.R. 915</b></p>	<p>ITALIANO</p> <p>Catalogo dei pezzi di ricambio</p>  <p><b>P.R. 915</b></p>	<p>NEDERLANDS</p> <p>Onderdelenboek</p>  <p><b>P.R. 915</b></p>	<p>SVENSKA</p> <p>Reservdelskatalog</p>  <p><b>P.R. 915</b></p>



Groupe Græftenhed (motor) Antriebsgruppe Power unit Grupo Gruppo Groep (motor) Drivaggregat	Moteur Motor Motor Engine Motor Motore Motor Motor	Inverseur réducteur Wendegetriebe Reversing and reduction gear Inversor reductor Invertitore riduttore Omkeerbak	Rapport Udvekslingsforhold Übersetzungsverhältnisse Ratio Relación Rapporto Verhouding Rapport
--	---	---	---

**X4M88S**

DIESEL INDENOR  
PEUGEOT  
XDP 4.88

SYNCHROMATIC  
947-10

1/1,73

**X4M90S**

DIESEL INDENOR  
PEUGEOT  
XDP 4.90

SYNCHROMATIC  
947-10

1/1,73

**X4M90AL/A**

DIESEL INDENOR  
PEUGEOT  
XDP 4.90

VELVET  
AS 1 70 CR  
AS 3 70 CR  
AS 5 70 CR  
AS 7 70 CR

1/1  
1/2,1  
1/2,9  
1/1,9



**02.01**

A

P.R. 915

**02.01**

A

P.R. 915

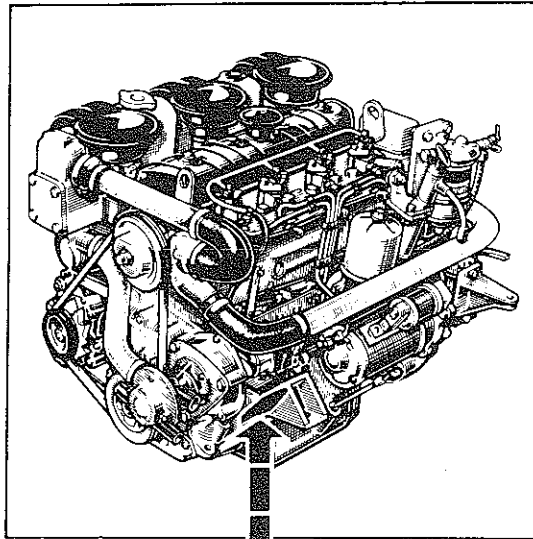

2

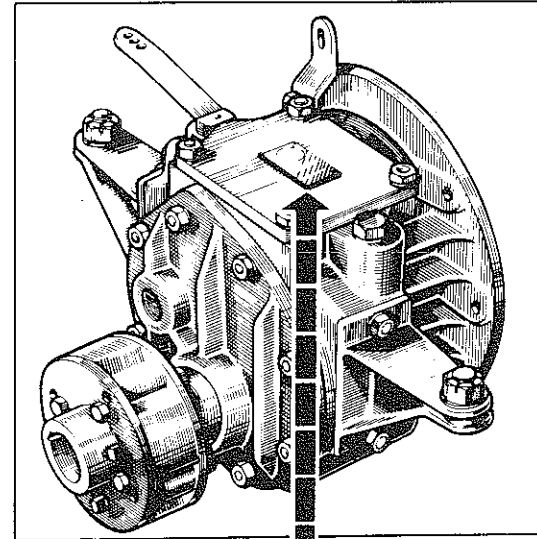

2





MOT. n° O...

77 03 001 202

33.50  
C P.R.0..

FRANÇAIS	DANSK	DEUTSCH	ENGLISH
<p><b>POUR COMMANDER DES PIÈCES DE RECHANGE, VEUILLEZ INDIQUER :</b></p> <ol style="list-style-type: none"> <li>Le type du groupe</li> <li>Le type et le numéro de fabrication de l'organe</li> <li>Le numéro de la pièce</li> <li>Facultatif : le numéro du catalogue, le numéro de la planche</li> </ol> <p>Si les autres N°s du groupe sont détruits : le numéro dans la série du type (voir carte de garantie)</p>	<p><b>VED BESTILLING AF RESERVEDELE BEDES DE VENLIGST OPGIVE :</b></p> <ol style="list-style-type: none"> <li>Gruppetypen</li> <li>Fabrikationsnummeret på det samlede aggregat</li> <li>Delnummeret</li> <li>Undtagelsesvis Katalognummeret Planchenummeret</li> </ol> <p>Hvis de andre gruppenumre er defekte : anvend chassisnummer (se garantikortet).</p>	<p><b>BEI DER BESTELLUNG VON ERSATZ-TEILEN IMMER ANGEBEN :</b></p> <ol style="list-style-type: none"> <li>Den Typ des Aggregates</li> <li>Typ und Fabrikationsnummer des Aggregates</li> <li>Die Teilnummer</li> <li>Wenn erforderlich : Die Nummer des Kataloges. Die Nummer der Bildtafel</li> </ol> <p>Sind alle anderen Nummern des Aggregates vernichtet : die Seriennummer des Fahrzeuges (siehe Garantiekarte)</p>	<p><b>WHEN ORDERING SPARE PARTS, WILL YOU PLEASE MENTION :</b></p> <ol style="list-style-type: none"> <li>The group type</li> <li>The unit type and manufacturing number</li> <li>The part number</li> <li>And optionally : the catalogue number and page number</li> </ol> <p>If the other group numbers are destroyed : the chassis number (see guarantee card).</p>
<p><b>ESPAÑOL</b></p> <p><b>AL SOLICITAR PIEZAS DE REPUESTO, SIRVANSE INDICAR :</b></p> <ol style="list-style-type: none"> <li>El tipo del grupo</li> <li>El tipo y el número de fabricación del órgano</li> <li>El número de la pieza</li> <li>Facultativo el número del catálogo, el número de la lámina</li> </ol> <p>Si los otros números del grupo son destruidos : el número en la serie del tipo (ver el certificado de garantía)</p>	<p><b>ITALIANO</b></p> <p><b>NELLE ORDINAZIONI DEI PEZZI DI RICAMBIO RICORDATE DI INDICARE :</b></p> <ol style="list-style-type: none"> <li>Il tipo del gruppo</li> <li>Il tipo ed il numero di fabbricazione dell'organo</li> <li>Il numero del pezzo</li> <li>Facoltativamente il numero di catalogo, il numero dell'illustrazione</li> </ol> <p>Se gli altri numeri del gruppo sono danneggiati : il numero della serie del tipo (vedi tessera di garanzia)</p>	<p><b>NEDERLANDS</b></p> <p><b>GELIEVE BIJ HET BESTELLEN VAN ONDERDELEN HET VOLGENDE OP TE GEVEN :</b></p> <ol style="list-style-type: none"> <li>Het type van de onderdeel groep</li> <li>Het type en het fabricagenummer van het orgaan</li> <li>Het onderdeelnummer</li> <li>Naar goedvinden : het onderdelenboeknummer, het afbeeldingsnummer</li> </ol> <p>Indien de overige nummers van de onderdeel groep onleesbaar zijn moet het fabricagenummer van de auto vermeld worden (zie garantie bewijs)</p>	<p><b>SVENSKA</b></p> <p><b>VID BESTÄLLNING AV RESERVDEL OMBEDES NI ATT ANGE :</b></p> <ol style="list-style-type: none"> <li>Drivaggregatstyp</li> <li>Enhetens fabrikationsnummer</li> <li>Delnummer</li> <li>Dessutom och valfritt : Katalognummer, Plansnummer</li> </ol> <p>Om drivaggregatets referensnummer saknas, ange chassisnumret (se garantikortet)</p>

## INTRODUCTION

Le présent document contient tous les ensembles et pièces détachées et vendables en rechange; il permet de déterminer avec précision leurs numéros et de les identifier facilement par les illustrations.

Ces ensembles et ces pièces sont répartis par **planche** suivant l'organe ou l'élément d'organe auquel ils se rattachent.

Chaque **planche** est identifiée par un numéro à 4 chiffres dont les deux premiers correspondent à un code organe déterminé; elle peut être caractérisée par une variante ou un point de départ dans le cas où elle s'identifie avec une planche similaire.

Une planche se compose:

de l'illustration des pièces et ensembles contenus dans la planche et qui diffèrent de forme; à chaque pièce illustrée correspond un ou plusieurs numéros de pièces caractérisés entre eux par une variante ou un signe codifié.

et, éventuellement, de **tableaux** comportant des renseignements complémentaires tels que points de départ et consignes. Ces tableaux figurent soit en bas de l'illustration, soit sur une page annexe à l'illustration.

**Remarque:** la signification des signes et expressions codifiés utilisés dans chaque planche, est indiquée dans la planche n° 05.

Un **répertoire numérique** en fin de catalogue donne la correspondance entre les numéros de pièces et les numéros de planches ainsi que les quantités de pièces par groupe dans la planche considérée, sauf pour les numéros de boulonnerie normalisée.

## UTILISATION

**Détermination du numéro d'une pièce** connaissant la nature de celle-ci:

1. Rechercher dans le **répertoire des planches** la planche correspondant à l'organe ou l'élément d'organe auquel cette pièce peut se rattacher.
2. Compulser le catalogue pour y retrouver cette planche en tenant compte éventuellement, du point de départ ou de la variante caractérisant la planche.
3. La planche étant déterminée, rechercher l'illustration de la pièce désirée.

A cette illustration correspond un ou plusieurs numéros. Choisir celui qui convient, compte tenu des signes ou expressions codifiés les caractérisant.

Les renvois numériques ou alphabétiques affectés aux numéros de pièces, assurent la liaison entre ces numéros et les renseignements complémentaires s'y rapportant, contenus dans les tableaux situés soit en bas de l'illustration soit en page annexe.

**Vérification**, par les Succursales Concessionnaires ou Centres Importateurs, d'un bon de commande, rédigé par un Agent ou un client ayant utilisé la documentation en sa possession.

1. Rechercher dans le **répertoire numérique**, au numéro de pièce donné par le bon de commande, les numéros de planches correspondantes.
2. Consulter ces planches pour vérifier si le numéro de pièce est bien celui qui convient compte tenu des points de départ affectés à ce numéro et du numéro de groupe ou d'organe pour lequel la pièce est commandée.

**Identification par l'illustration** d'une pièce dont on connaît le numéro.

1. Rechercher dans le répertoire numérique, au numéro de pièce donné, le numéro des planches correspondantes.
2. Consulter ces planches.

## CONDITIONS GÉNÉRALES DE VENTE

Voir les tarifs de pièces de rechange

## INDLEDNING

Nærværende katalog indeholder alle enheder samt alle monterede originale løsdeler, som er salgbare ved udskiftning; det er med lethed muligt at identificere delene ved hjælp af illustrationerne. Disse samlede enheder og løsdeler er fordelt på **plancher**, idet de er vist i forbindelse med vogndelen eller enheden, hvorpå de skal monteres.

Hver **planche** er mærket med et nummer bestående af 4 tal, hvoraf de to første svarer til et kodetal på en bestemt vognedel; hvor flere plancher er identiske er disse yderligere tilføjet bemærkning med angivelse af afvigelse eller begrænsninger af delenes anvendelse.

En planche består af: illustration af forskellige dele og sæt; til hver del svarer et eller flere numre, som man skelner ved en afvigelse eller et kodetegn.

og eventuelt **tabeller**, som indeholder oplysninger om begrænsninger af delenes anvendelse, samt over forskellige dimensioner o. l.. Disse tabeller står enten forneden på illustrationen eller på en tillægsside.

**Bemærkning:** Forklaring på kodetegn og kodeudtryk, som bruges på plancherne, er opgivet på planche no. 05.

En **nummerfortegnelse** sidst i kataloget viser, hvorledes delnumre og planchenumre svarer til hinanden og viser også delantal pr. kraftenhed (motor) på den pågældende planche, undtagen for de normale bolte, skruer og møtrikker.

## ANVENDELSE

**Fastsættelse af nummeret på en del man kender:**

1. Find i registeret over **plancher** den **planche**, som svarer til den vognedel eller enhed på hvilken reservedelen er beregnet til at blive monteret.
  2. Slå op i kataloget og find denne planche, idet De holder Dem til eventuelle afvigelser og kodetegn der måtte stå på planchen.
  3. Når den rigtige planche er fundet, find da billedet af den ønskede del; til dette billede svarer et eller flere numre; vælg det, der passer i henhold til kodetegn eller kodeudtryk.
- De med tal eller bogstaver mærkede henvisninger ved delnummeret gør det muligt at finde forbindelsen mellem disse numre og de yderligere oplysninger der findes enten nederst på planchen eller på tillægssiden.

**Ordresedler**, der udstedes af en agent eller en kunde ved hjælp af vedlagte reservedelskatalog, skal kontrolleres af den koncessionerede forhandler eller af importøren.

1. Find i registeret over reservedelsnumre **nummeret** på den **planche**, som reservedelsnummeret henviser til.
2. Se på plancherne for at afgøre om det er de rigtige numre, idet De holder Dem til eventuelle afvigelser og kodetegn samt kraftenhedsnummeret som delene er bestilt til.

**Fastsættelse ved hjælp af illustration** af en del, hvis nummer man kender.

1. Find i registeret over reservedelsnumre **nummeret** på den **planche**, som reservedelsnummeret henviser til.
2. Slå op på planchen.

## ALMINDELIGE SALGSBETINGELSER

Se reservedels-prislisten

## VORWORT

Die vorliegende Ausgabe enthält alle montierten Einzelteile, die als Ersatzteile verkäuflich sind. Sie ermöglicht es, die Nummern mit Genauigkeit zu bestimmen und sie anhand der Abbildungen zu identifizieren.

Diese Aggregate und Teile sind in **Bildtafeln** aufgeteilt, und zwar ihrer Zugehörigkeit entsprechend.

Jede **Bildtafel** ist mit einer vierstelligen Nummer versehen, wovon die ersten zwei Ziffern einem bestimmten Organ-Schlüssel entsprechen; sie kann durch eine Variante oder einen Ausgangspunkt der Ersatzteilnummer gekennzeichnet sein, wenn sie mit einer gleichartigen Bildtafel übereinstimmt.

Eine **Bildtafel** besteht aus:

den Abbildungen der Aggregate und Teile, die in der Form voneinander abweichen; jedem dargestellten Teil entsprechen eine oder mehrere Teilnummern, untereinander gekennzeichnet durch eine Variante oder ein verschlüsseltes Zeichen.

Besonderen **Tabellen** mit zusätzlichen Angaben, wie z.B. Ausgangspunkt einer Ersatzteilnummer, oder Hinweisen (für die verschiedenen Ausführungen bzw. Änderungen).

**Anmerkung:** Die Erklärung der Zeichen und verschlüsselten Ausdrücke, die auf den Bildtafeln erscheinen, ist auf Seite 05. zu ersehen.

Am Ende des Kataloges finden Sie ein numerisches Sachverzeichnis, aus dem folgendes zu ersehen ist: die Ersatzteilnummer, die dazugehörige Bildtafelnummer und die Anzahl gleicher Teile pro Antriebsgruppe auf der Tafel. Ausgenommen sind die Nummern der genormten

## GEBRAUCHSANWEISUNG

**Bestimmung der Nummer eines Teiles**, dessen Beschaffenheit bekannt ist:

1. Im **Bildtafelverzeichnis** die Nummer der Bildtafel suchen, zu der das Teil oder Aggregat gehört.
2. Im Katalog diese Bildtafel nachschlagen und gegebenenfalls die Variante oder den Ausgangspunkt, die die Bildtafel kennzeichnen, berücksichtigen.
3. Für das Teil ist — auf der Bildtafel — eine oder mehrere Nummern angegeben. Bei der Wahl der richtigen Nummer sind eventuelle verschlüsselte Zeichen und Ausdrücke zu berücksichtigen. Anstelle der Ersatzteilnummer erscheint sehr oft eine einzelne Zahl. Dieselbe wird unten auf der Bildtafel wiederholt und weist auf zusätzliche Angaben hin.

**Prüfen eines Bestellscheines**, den ein Unterhändler oder Kunde mit der ihm zur Verfügung stehender Fachliteratur (Kataloge usw.) ausgestellt hat.

1. Im **numerischen Sachregister** unter der auf dem Bestellschein angegebenen Teilnummer die entsprechende Bildtafel suchen.
2. Die Bildtafel aufschlagen und prüfen, ob die angegebene Nummer richtig ist. Daher müssen die vorher schon genannten besonderen Hinweise beachtet werden.

**Identifizierung eines Teiles**, dessen Nummer bekannt ist, anhand der Abbildung:

1. Im numerischen Sachregister unter der bekannten Teilnummer die Nummer der entsprechenden Bildtafel heraussuchen.
2. Diese Bildtafel zu Rate ziehen.

## ALLGEMEINE VERKAUFSBEDINGUNGEN

Siehe Ersatzteil-Preisliste

## INTRODUCTION

This document contains all the assemblies and parts sold as spares; it enables one to determine with precision their numbers and to identify them easily by the illustrations. These assemblies and these parts are set out in illustrated plates according to the unit or sub-assembly to which they belong. Each plate is identified by a four figure number, the first two of which correspond to a specified unit code; it may be distinguished by a variant or a starting point in the case where it is identifiable with a similar plate.

A plate consists of: the illustration of parts and assemblies contained in the plate and which differ in shape; to each part shown corresponds one or several part numbers distinguished one from the other by a variant or a code sign, and when necessary, tables showing additional information such as starting point, and instructions. These tables figure either at the bottom of the illustration or on a page added to the illustration.

**Note :** The meaning of the code signs and expressions used on each plate, is indicated on plate n° 05.

A numerical index at the end of the catalogue gives the relationship between the part numbers and the plate numbers, also the quantity of parts per power unit in the plate under consideration, except for the numbers of standard nuts and bolts.

## USE

**Ascertaining a part Number** knowing the nature of this part :

1. In the plate index, find the plate corresponding to the unit or sub-assembly to which this part may be attached.
2. Consult the catalogue to find this plate, when necessary taking into account the starting point or the variant distinguishing this plate.
3. Having found the plate, look for the illustration of the desired part. One or several numbers correspond to this illustration; choose the suitable number, taking into account code signs or expressions which distinguish them.

The numerical or alphabetical reference marks added to the part number, ensure the connection between these numbers and the additional information appertaining to them, included in the tables found at the bottom of the illustration or on the additional page.

**Checking by Branches, Distributors or Importation Centres of an Order Form** which has been filled in by an Agent or by a client using the documents in his possession.

1. In the numerical index, at the part number indicated on the order form, find the corresponding plate numbers.
2. Examine these plates to check that the part number given is correct taking into account the starting points added to this number and the number of the power unit or unit for which the part has been ordered.

**Identifying by the illustration** a part the number of which is known.

1. In the numerical index, at the given part number find the corresponding plate numbers.
2. Consult these plates.

## GENERAL SALES CONDITIONS

See the spare parts price lists

## INTRODUCCION

Este documento contiene todos los conjuntos y las piezas sueltas vendidas como repuestos; con él, los números se hallan con precisión y por medio de las láminas se les puede identificar con toda facilidad.

Estos conjuntos y piezas van repartidos por láminas, según el órgano o el elemento de órgano al que pertenecen.

Todas las láminas llevan un número de cuatro cifras, las dos primeras de las cuales corresponden a la anotación codificada del órgano; cuando la lámina pueda confundirse con otra similar, lleva especificada la variante en cuestión o el número del punto de partida.

Una lámina consta: de la ilustración de las piezas y conjuntos contenidos en ella y que difieren de forma; cada una de las piezas ilustradas lleva uno o varios números de piezas, caracterizados entre sí por una variante o un signo convencional, y, a veces, de cuadros donde figuran informes complementarios, tales como los puntos de partida, y las consignas. Estos cuadros se encuentran en una hoja anéx a la ilustración o en la parte inferior de la lámina.

**Observación :** El significado de los signos y expresiones convencionales empleados en las láminas figura en la lámina 05.

La lista numérica, inserta al final del Catálogo, da la correspondencia entre los números de las piezas y los de las láminas y las cantidades de piezas por grupo que hay en la lámina considerada, excepto para los números de la tornillería normalizada.

## MODO DE EMPLEO

**Determinación del número de una pieza,** conociendo la naturaleza de la misma :

1. Buscar en la lista de láminas, la lámina correspondiente al órgano o al elemento de órgano al que la pieza puede pertenecer.
  2. Consultar el Catálogo y buscar la lámina, teniendo en cuenta en caso preciso, el punto de partida o la variante característica de la lámina.
  3. Una vez encontrada la lámina, buscar la ilustración de la pieza deseada. A esta ilustración corresponde uno o varios números; elegir entre ellos el que conviene, habida cuenta de los signos o expresiones convencionales que le acompañan.
- Las citas numéricas o alfabéticas que acompañan al número de pieza sirven para unirlo a los informes complementarios que le conciernen; estos informes se hallan en la parte inferior de la página o en hoja anéx a (cuadros).

**Verificación por las Sucursales, Concesionarios o los Centros Importadores, de un vale de pedido,** redactado por un agente o un cliente, a base de la documentación que posee.

1. Buscar en la lista numérica, en el número de pieza señalado por el pedido, los números de las láminas correspondientes.
2. Consultar las láminas para comprobar si el número de la pieza es el que conviene, habida cuenta de los puntos de partida correspondientes a ese número y del número del grupo o del órgano para el que se pide la pieza.

**Identificación por la ilustración** de una pieza cuyo número se conoce.

1. Buscar en la lista numérica, en el número de pieza dado, el número de las láminas correspondientes.
2. Consultar estas láminas.

## CONDICIONES GENERALES DE VENTA

Véanse las tarifas de las piezas de recambio

## PREMESSA

La presente raccolta contiene tutti i gruppi e i pezzi staccati, venduti come ricambi; permette di determinare con precisione i loro numeri e di identificarli facilmente per mezzo delle illustrazioni. Questi gruppi e questi pezzi sono ripartiti per Tavole secondo l'organo o l'elemento di organo ai quali si riferiscono.

Ogni Tavola è identificata da un numero a 4 cifre delle quali le prime due corrispondono ad un determinato codice degli organi; può essere caratterizzata da una variante od un punto di partenza nel caso in cui essa si identifichi con una tavola similare.

Una tavola si compone: dell'illustrazione dei pezzi e gruppi contenuti nella tavola e che sono di forme differenti; ad ogni pezzo illustrato corrisponde uno o più numeri di pezzo caratterizzati fra essi da una variante o da un segno codificato.

ed eventualmente, da Tabelle che comportano delle informazioni complementari come il punto di partenza e istruzioni particolari. Queste tabelle figurano sia sotto l'illustrazione, sia su una pagina allegata all'illustrazione.

**Osservazione :** il significato dei segni ed espressioni codificate impiegate in ogni tavola è indicato nella tavola n° 05

Un indice numerico, alla fine del catalogo, fornisce la corrispondenza fra i numeri dei pezzi ed i numeri delle tavole come pure le quantità di pezzi per gruppo nella tavola considerata, eccetto per i numeri di bulloneria normalizzata.

## USO DEL CATALOGO

**Determinazione del numero di un pezzo** conoscendo la sua natura :

1. Cercare nell'indice delle tavole, la tavola corrispondente all'organo o all'elemento di organo al quale questo pezzo può riferirsi.
2. Consultare il Catalogo per trovare questa tavola tenendo conto eventualmente, del punto di partenza o della variante che caratterizza la tavola.
3. Determinata la tavola, cercare l'illustrazione del pezzo desiderato. A questa illustrazione corrispondono uno o più numeri; scegliere quello che conviene, tenendo conto dei segni od espressioni codificate che li caratterizzano. I rinvii numerici od alfabetici in corrispondenza del numero del pezzo, assicurano il collegamento fra questi numeri e le informazioni complementari che vi si riferiscono, contenuti nelle tabelle situate sia in calce all'illustrazione, sia nella pagina allegata.

**Verifica,** dalle Sucursali, Concessionari o Centri Importatori, di un buono di ordinazione, redatto da un Agente o da un cliente che avrebbe usato la documentazione in suo possesso.

1. Cercare nell'indice numerico, al numero di pezzo dato dal buono di ordinazione, i numeri delle tavole corrispondenti.
2. Consultare queste tavole per controllare se il numero del pezzo è quello che corrisponde tenendo conto dei punti di partenza attribuiti a questo numero e del numero del gruppo o dell'organo per il quale il pezzo è stato ordinato.

**Identificazione per mezzo dell'illustrazione** di un pezzo del quale si conosce il numero.

1. Cercare nell'indice numerico, al numero di pezzo dato, il numero delle tavole corrispondenti.
2. Consultare queste tavole.

## CONDIZIONI GENERALI DI VENDITA

Vedi tariffa pezzi di ricambio

## INLEIDING

In deze catalogus zijn alle onderdeelgroepen en afzonderlijke onderdelen vermeld welke voor reparatiedoeleinden worden verkocht. De onderdelen zijn met de juiste nummers aangeduid en kunnen aan de hand van de afbeeldingen gemakkelijk worden geïdentificeerd.

De onderdeelgroepen en afzonderlijke onderdelen zijn in elke plaat gegroepeerd volgens het orgaan of deel van het orgaan waartoe zij behoren.

Iedere plaat is aangeduid met een nummer van vier cijfers, waarvan de eerste twee cijfers corresponderen met een code voor het betreffende orgaan. Hiervan kan zijn afgeweken in geval de aanduiding betrekking heeft op een overeenkomstige plaat.

Een plaat bestaat uit :

de afbeelding van de onderdelen en onderdeelgroepen welke in de plaat zijn opgenomen en welke in vorm verschillen ; met elk afgebeeld onderdeel correspondeert een nummer of meerdere nummers welke onderling gekenmerkt zijn door een afzonderlijke variërende aanduiding of een code-merkteken.

en eventueel uit een tabel waarin aanvullende gegevens zijn vermeld, zoals begin van uitgave en verdere aanduidingen. Deze tabellen zijn geplaatst, hetzij onderaan de afbeelding, hetzij op de bladzijde naast de afbeelding.

**Opmerkingen :** De verklaring van de betekenis van de in elke lijst gebruikte aanduidingen en code-merken is in de lijst no. 05. opgenomen.

Achterin de catalogus is een **numerieke inhoudsopgave** opgenomen, waarin de onderdeelnummers en de daarmee corresponderende nummers van de betreffende platen zijn vermeld, evenals het aantal onderdelen per groep (motor) met uitzondering van het aantal genormaliseerde bouten.

## GEBRUIKSAANWIJZING

**Bepalen van het onderdeelnummer** wanneer de soort van het onderdeel bekend is

1. Zoek in de **inhoudsopgave** de **plaat** welke betrekking heeft op het orgaan waarvan het betreffende onderdeel deel uitmaakt.
2. Zoek in de catalogus deze plaat op, rekening houdend met eventueel afwijkende gegevens, zoals begin van uitgave en afwijkende aanduiding welke de plaat kenmerken.
3. Wanneer de plaat gevonden is, zoekt men daarin de afbeelding van het gewenste onderdeel op. Bij deze afbeelding staan één of meer nummers ; kies hieruit het juiste nummer, rekening houdend met de kenmerkende codemerkttekens of aanduidingen. De aanduidingen in cijfers of letters bij het onderdeelnummer verwijzen naar de aanvullende nummers en aanwijzingen (indien van toepassing), welke zijn vermeld in de tabellen onder de plaat of op de tegenoverliggende bladzijde.

**Controle door de filialen, agenten of importeurs van een bestelbon**, opgesteld door een subagent of een client, die gebruik heeft gemaakt van de in zijn bezit zijnde documentatie.

1. Zoek in de **numerieke inhoudsopgave** aan de hand van het in de bestelbon gegeven onderdeelnummer de betreffende plaatnummers op.
2. Raadpleeg de platen om te controleren of het opgegeven onderdeelnummer wel het juiste is, rekening houdend met begin van uitgave van het nummer en het groepnummer of nummer van het orgaan waarvoor het onderdeel wordt besteld.

**Identificatie van een onderdeel aan de hand van de afbeelding**, wanneer het onderdeelnummer bekend is.

1. Zoek het nummer van de betreffende platen aan de hand van het juiste onderdeelnummer in de numerieke inhoudsopgave.
2. Raadpleeg de platen.

## ALGEMENE VERKOOPSVORWAARDEN

Zie de onderdelentarievenlijsten

## INLEDNING

Föreliggande katalog innehåller en förteckning över reservdelar och kompletta enheter, som kan monteras vid reparation. Den gör det möjligt att exakt fastställa delarnas nummer och att identifiera dem med ledning av illustrationerna.

Varje detalj och varje enhet kan återfinnas på en bild, föreställande den huvudenhet i vilken detaljen ingår.

Varje planschside har ett 4-siffrigt nummer av vilket de två första siffrorna motsvarar en kodbeteckning för huvudenheten eller organet ifråga ; avbildningen kan ha en variant eller en konstruktionsändring med utgång från ett visst fabriktionsnummer och i sådant fall finnes två likartade planscher .

En plansch består av :

Avbildning av delarna och den enhet i vilken dessa ingår ; till varje avbildad detalj svarar ett eller flera reservdelsnummer som sinsemellan karakteriseras genom en variant eller en kodbeteckning.

Eventuellt av en tablå, som ger kompletterande upplysningar såsom från vilket fabriktionsnummer en viss detalj monteras och vilka delar, som erfordras vid utbyte. Dessa tablåer återfinnes antingen längst ned på planschen eller på ett blad intill planschen.

**Anmärkning :** Förklaring till de märken och kodbeteckningar, som finnes på varje plansch, återfinnes på plansch nr. 05.

I slutet av katalogen finnes en **referenslista** mellan reservdelsnummer och planschnummer såväl som uppgift på det antal, som åtgår av varje detalj, (med undantag för numren på bultar av standardtyp).

## ANVÄNDNING

**Fastställande av numret på en viss reservdel** tillgås på följande sätt :

1. Sök i **bildregistret** upp den bild som omfattar den huvudenhet i vilken den aktuella delen ingår eller med vilken den sammanhängar.
2. Sök upp denna plansch i katalogen och tag därvid hänsyn till eventuellt förekommande variant- eller fabriktionsnummer.
3. Då den önskade planschen återfunnits skall den eftersökta delen uppsökas. Till den avbildade delen finnes ett eller flera reservdelsnummer och man skall välja det nummer, som motsvarar de märken eller kodbeteckningar som betecknar den del man vill ha.

De siffror eller bokstäver som kan förekomma framför eller efter ett reservdelsnummer hänvisar till kompletterande upplysningar om detaljen och återfinnes i en tablå längst ned på sidan eller på vidstående sida.

**Filialers och centralimportörers kontroll av beställningssedel**, som utskrivits av en representant eller en kund med ledning av tillgänglig dokumentation.

1. Leta i nummerregistret med ledning av det reservdelsnummer som framgår av beställningssedeln, reda på numret på motsvarande bild.
2. Kontrollera med ledning av planschen att det uppgivna reservdelsnumret är det riktiga med hänsyn till det uppgivna fabriktionsnumret.

**Identifiering med ledning** av en bild av en detalj vars nummerbeteckning är känd :

1. Sök med ledning av nummerregistret upp numret på den bild som upptar den aktuella detaljen.
2. Slå upp denna bild.

## ALLMÄNNA FÖRSÄLJNINGSVILLKOR

Se Reservdelsprislista

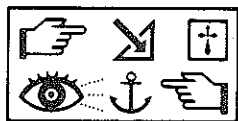

**05.01**

A P.R. 915

**05.01**

A P.R. 915

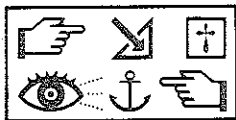

	FRANÇAIS	DEUTSCH	ESPAÑOL	NEDERLANDS
	ENGLISH	DANSK	ITALIANO	SVENSKA
†	Pièce à épuiser. Use up stock.	Auslaufende Teile. Dele til at opbruge.	Pieza que hay que agotar. Pezzo da esaurire.	Onderdeel komt te vervallen : levering zolang de voorraad strekt. Utforsäljes.
⊕	Après épuisement, prévoir. After exhaustion of stock, supply.	Nach Auslaufen vorsehen. Efter udgået lager bestil.	Una vez agotada, prever. Dopo esaurimento prevedere.	Te gebruiken nadat de bestaande voorraad is uitgeput. Efter utförsäljning levereras.
👁️	Voir planche ou voir page. "See plate " or " see page "	Siehe Bildtafel oder Seite. Se planche eller se side.	Ver lámina o ver página. Vedere tavola o vedere pagina.	Zie afbeelding of blz. Se plansch eller sida.
↘	Pour. For.	Für. Til.	Para. Per.	Voor. For.
↗	Sauf. Except.	Ausser. Uden.	Excepto. Eccetto.	Uitgezonderd. Utom.
□	Équipement facultatif. Optional equipment.	Ausrüstung nach Wunsch. Valgfrit udstyr.	Equipo opcional. Equipaggiamento facoltativo.	Behoort niet tot de standaard-uitrusting. Valfrit utrustning.
➡	..... à ..... ..... to .....	..... bis ..... ..... til .....	..... a ..... ..... a .....	..... tot ..... ..... till .....
&	et And.	Und. og.	y e	en. Och.
⚖️	Pièces à prévoir en supplément. Supplementary parts to be foreseen.	Teile zusätzlich vorzusehen. Bestilling af ekstradele.	Piezas suplementarias. Pezzi da prevedere in supplemento.	Aanvullend in voorraad te nemen onderdelen. Supplementdelar.
❓	Consignes d'interchangeabilité. Interchangeability instructions symbolised by.	Anweisungen für die Auswechslung, symbolisiert durch. Når udskifning tilrådes, bruges følgende tegn.	Consignas de intercambiabilidad, simbolizadas por. Istruzioni per l'intercambiabilità simbolizzati da.	Aanwijzingen betreffende verwissel- baarheid, aangeduid door. Anvisningar för utbyte.

**05.02**

A P.R. 915

**05.02**

A P.R. 915

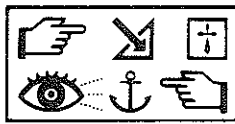

	Numéros de véhicules ou d'organes. Numbers of vehicles or units in question symbolised by.	Nummern der betreffenden Fahrzeuge oder Organe symbolisiert durch. Det pågældende vognummer eller aggregatnummer med.	Números de vehículos o de órganos interesados, simbolizados por. Numeri dei veicoli o degli organi interessati simbolizzati da.	Serienummer van de betreffende wagens of organen aangeduid door. Vagn eller organ tillverkningsnummer.
	Denture extérieure : Nombre de dents. (exemple 10 dents) External teeth : Number of teeth (For Example : 10 teeth)	Aussere Verzahnung : Anzahl der Zähne (Beispiel : 10 Zähne) Udvendige tænder : Antal tænder (For eksempel : 10 tænder)	Dentado exterior : Número de dientes (ejemplo 10 dientes) Dentatura esterna : numero dei denti (esempio : 10 denti)	Uitwendige vertanding : Aantal tanden (voorbeeld : 10 tanden) Bommar, utvändig : Antal (exempel : 10 st)
	Denture intérieure : Nombre de dents. (exemple 10 dents) Internal teeth : Number of teeth (For Example : 10 teeth)	Innere Verzahnung : Anzahl der Zähne (Beispiel : 10 Zähne) Udvendige tænder : Antal tænder (For eksempel : 10 tænder)	Dentado interior : Número de dientes (ejemplo : 10 dientes) Dentatura interna : numero dei denti (esempio : 10 denti)	Inwendige vertanding : Aantal tanden (voorbeeld : 10 tanden) Bommar, invändig : Antal (exempel : 10 st)
	Nombre de dents. Number of teeth.	Anzahl der Zähne. Tandantal.	Número de dientes. Numero di denti.	Aantal tanden. Antal kuggar.
	Unité de vente. Sold in following quantities.	Verkaufseinheit. Salgsenhed.	Unidad de venta. Unità di vendita.	Verkoopseenheid. Försäljningslängd.
	Vente en longueur de fabrication. Sold in manufactured length.	Verkauf nach Fabrikationslängen. Salg efter fabrikationslængde.	Venta a la longitud de fabricación. Vendita in lunghezza di fabbricazione.	Verkoop in fabricagelengte. Försäljning per tillverkningslängd.
	Ou bien. Or.	Oder. Eller.	O bien. Oppure.	Of wel. Eller.
	Admission. Inlet.	Einlass. Indsugning.	Admisión. Aspirazione.	Inlaat. Insugning.
	Échappement. Exhaust.	Auspuff. Udblæsning.	Escape. Scarico.	Uitlaat. Avgassystem.
	Conditions spéciales d'échange. Special conditions for replacement.	Spezial-Austauschbedingungen.	Condiciones generales de cambio. Speciali condizioni per la sostituzione.	Speciale ruil condities Villkor för speciell utbytesservice.
	Pièces vendues en collection sous un seul numéro. Parts sold as a kit under one part number	Unter einer einzigen Nummer als Satz verkaufte Teile	Piezas vendidas por colecciones bajo un solo número Parti vendute in serie con un'unico numero	Onderdelen, die als set onder één nummer verkocht worden.

**05.03**

A P.R. 915

**05.03**

A P.R. 915



	Inverseur à commande mécanique.	Mechanisch betätigter Umschalter.	Inversor de mando mecánico.	Mechanisch bediende schakelaar
	Mechanically operated reversing gear.	Mekanisk styret kontakt	Invertitore a comando meccanico.	
	Inverseur à commande hydraulique.	Hydraulisch betätigter Umschalter.	Inversor de mando hidraulico.	Hydraulisch bediende schakelaar
	Hydraulically operated reversing gear.	Hydraulisk styret kontakt	Invertitore a comando idraulico.	
	Emplacement du marquage sur l'ensemble ou la pièce.	Lage der Markierung am Teil oder an der Baugruppe.	Emplazamiento de la marca en el conjunto o en la pieza.	Plaats van het typeplaatje van de groep of het onderdeel.
	Position of the marking on the assembly or the part.	Placering af mærkningen på enheden eller delen.	Spazio riservato al contrassegno di riferimento sul complessivo o sulla parte.	Plats for typskylt.
	Gratuit	Gratis	Gratuito	
	Free of charge		Gratuito	
	Payant	zahlend	De pago	
	Chargeable		A pagamento	
	Édition totale	Gesamtauflage	Edición total	
	Full edition		Edizione totale	
<b>GRO</b>	Groupe	Antriebsgruppe.	Grupo.	Groep. (motor).
	Power unit.	Kraftenhed (motor).	Gruppo.	Drivaggregat.
<b>MEC</b>	Mécanisme.	Mechanismus.	Mecanismo.	Mechanisme.
	Mechanism	Mekanisme.	Meccanismo.	Mekanism.
<b>MOT</b>	Moteur.	Motor.	Motor.	Motor.
	Engine.	Motor.	Motore.	Motor.
<b>PPE INJ</b>	Pompe d'injection.	Einspritzpumpe.	Bomba de inyección.	Brandstofpomp.
	Injection pump.	Indsprøjtningpumpe	Pompa iniezione.	Insprutningspump.
<b>RAP</b>	Rapport.	Übersetzungsverhältnisse	Relación	Verhouding
	Ratio	Udvekslingsforhold	Rapporto	Rapport.

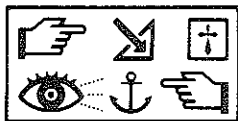

**05.04**

A P.R. 915

**05.04**

A P.R. 915



SI

Système international.	Internationales System.	Sistema internacional.	Internationaal Systeem.
International system.	Internationalt system.	Sistema internazionale.	Internationellt system.
Les poids et mesures sont indiqués en système métrique.	Gewichte und Längenmasse sind nach dem Dezimalsystem aufgeführt.	Los pesos y medidas se indican en el sistema métrico.	Maten en gewichten zijn in metrische waarden opgegeven.
Weights and measures are in metric units.	Vægt og mål er anført efter det metriske system.	I pesi e le misure sono indicati secondo il sistema metrico.	Vikt och längd enligt decimal- och meter-system.
Les cotes non suivies de symbole sont en millimètres.	Masse ohne Einheitsangabe sind in Millimetern ausgedrückt.	Las cotas no seguidas de simbolo indican milímetros.	De maten waar geen teken achter staat zijn in millimeters.
Those dimension which have no following symbol are in millimetres.	Mål uden signaturforklaring er mm.	Le quote non seguite dal simbolo sono in millimetri.	När beteckning saknas är längden angiven i millimeter.



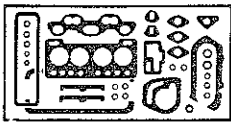

**20.05**  
A P.R. 915

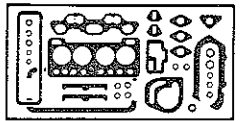

**20.05**  
A P.R. 915

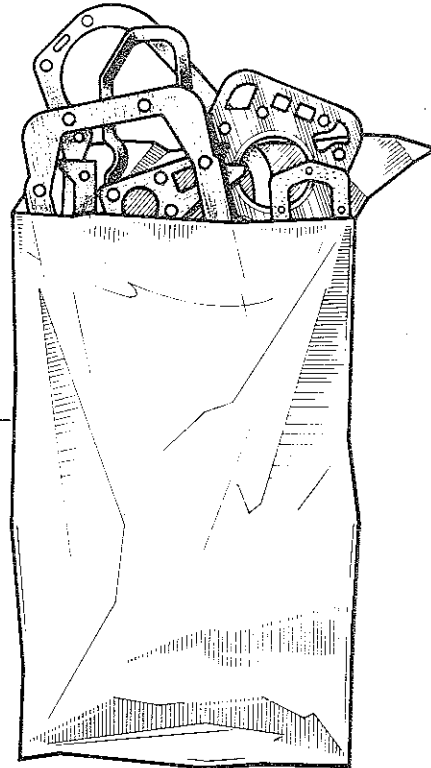

(XDP 4.88)79 02 000 002}  
(XDP 4.90)79 02 000 357}

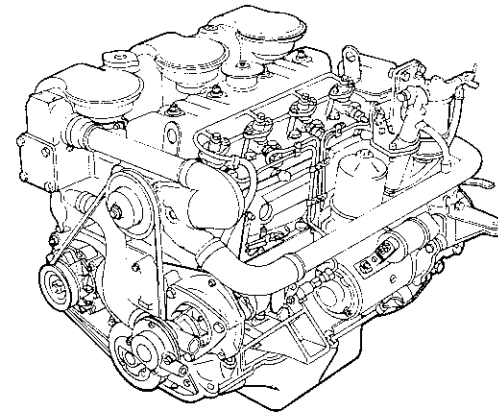

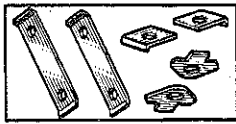

**20.10**

A P.R. 915

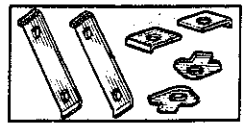

**20.10**

A P.R. 915

79 02 000 003

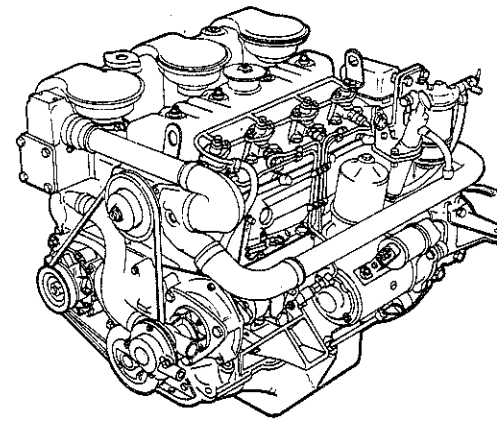
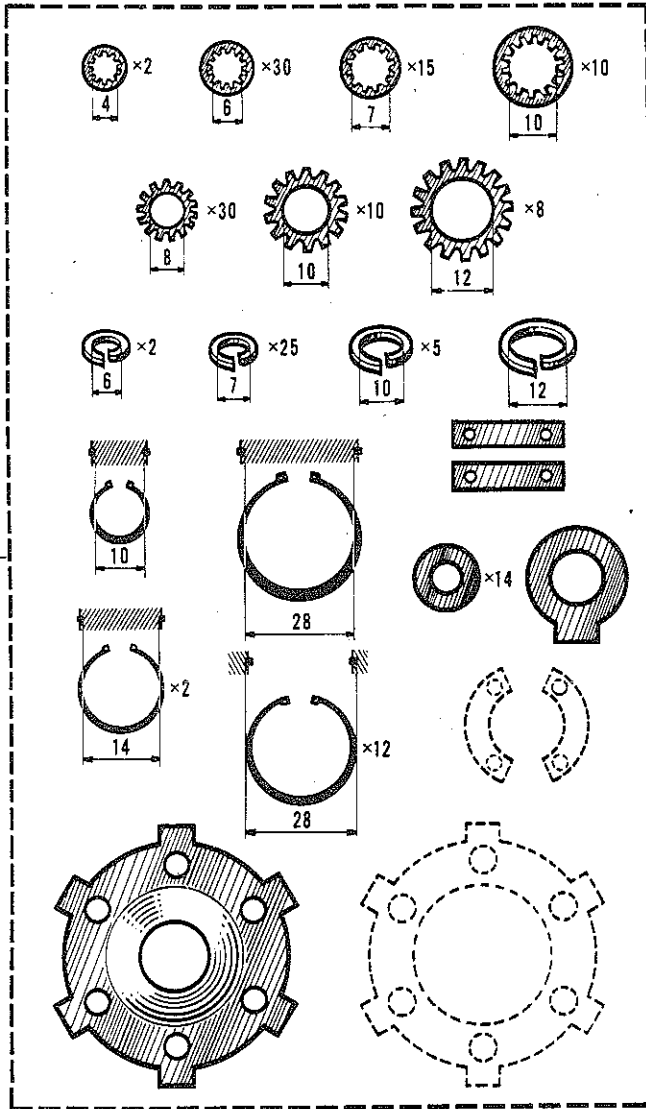

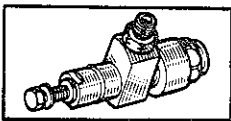

**21.05**

A P.R.915

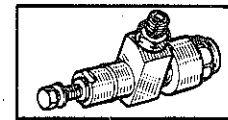

**21.05**

A P.R.915

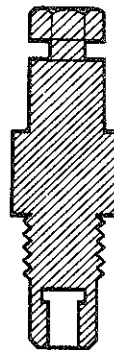

75 63 356 000

RDN12SD6517

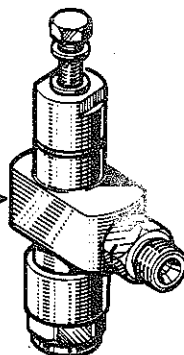

RKB35S5118  
RKB35S5246

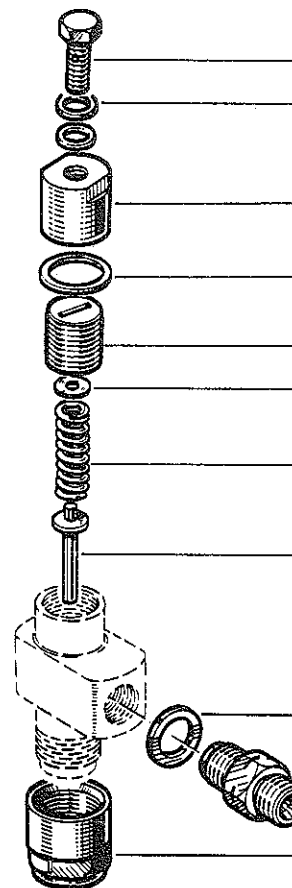

08 55 242 800

08 55 242 900

08 55 243 000

08 55 243 100

{ 08 55 243 200 (1)

{ 08 55 273 900 (2)

08 55 243 300

{ 08 70 047 200 (1)

{ 08 55 274 000 (2)

77 01 004 555

08 55 243 800 (1)

{ 77 01 000 621 (1)

{ 77 01 007 206 (2)

08 55 243 600

77 01 000 620 †

77 01 005 948

(1) 77 01 000 620

(2) 77 01 005 948

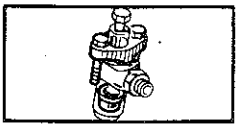

**21.40**

A P.R. 915

**21.40**

A P.R. 915

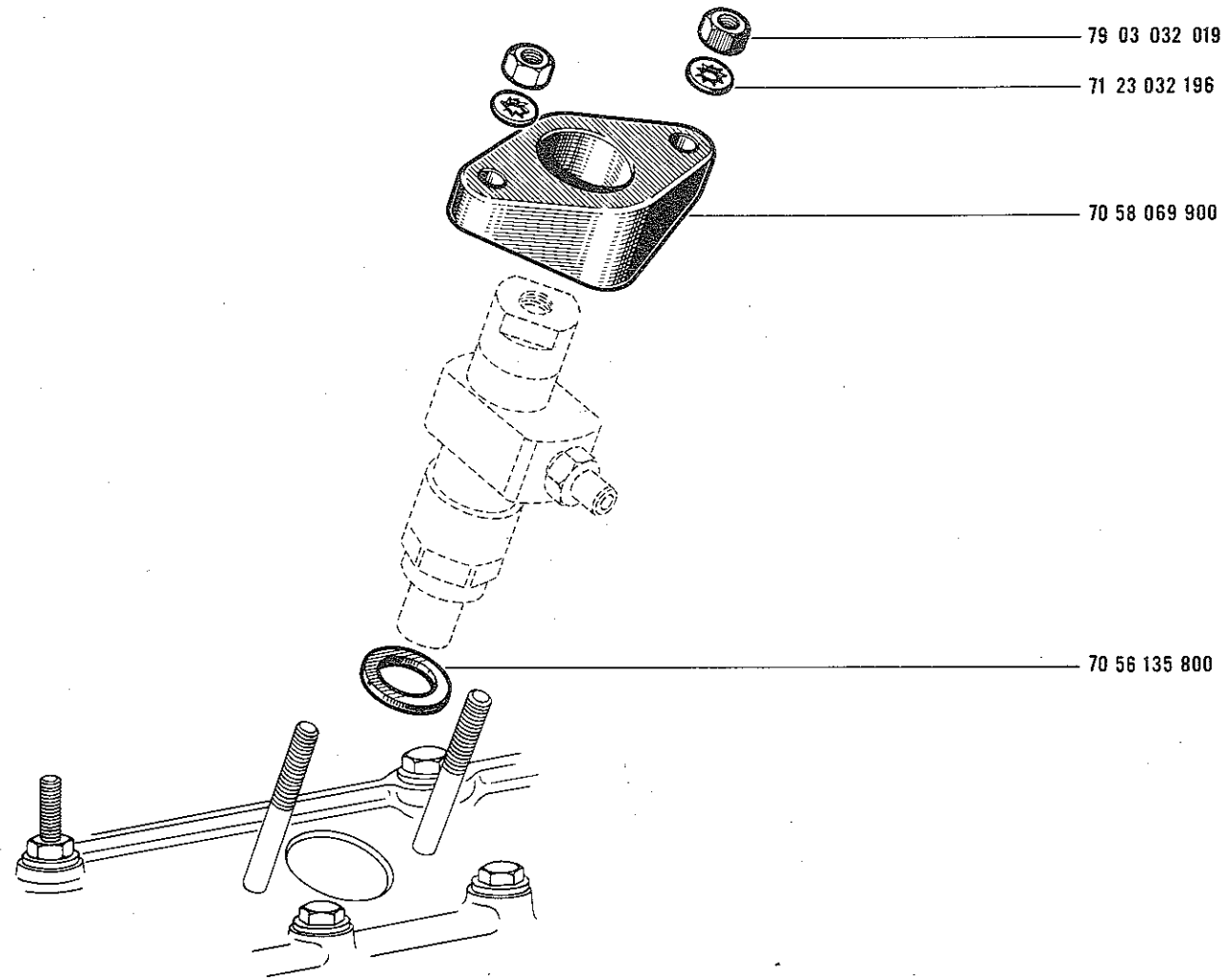
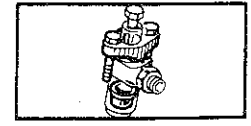

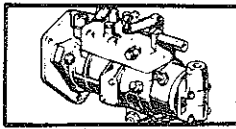

**22.01**

A P.R.915

XDP 4.88

**22.01**

A P.R.915

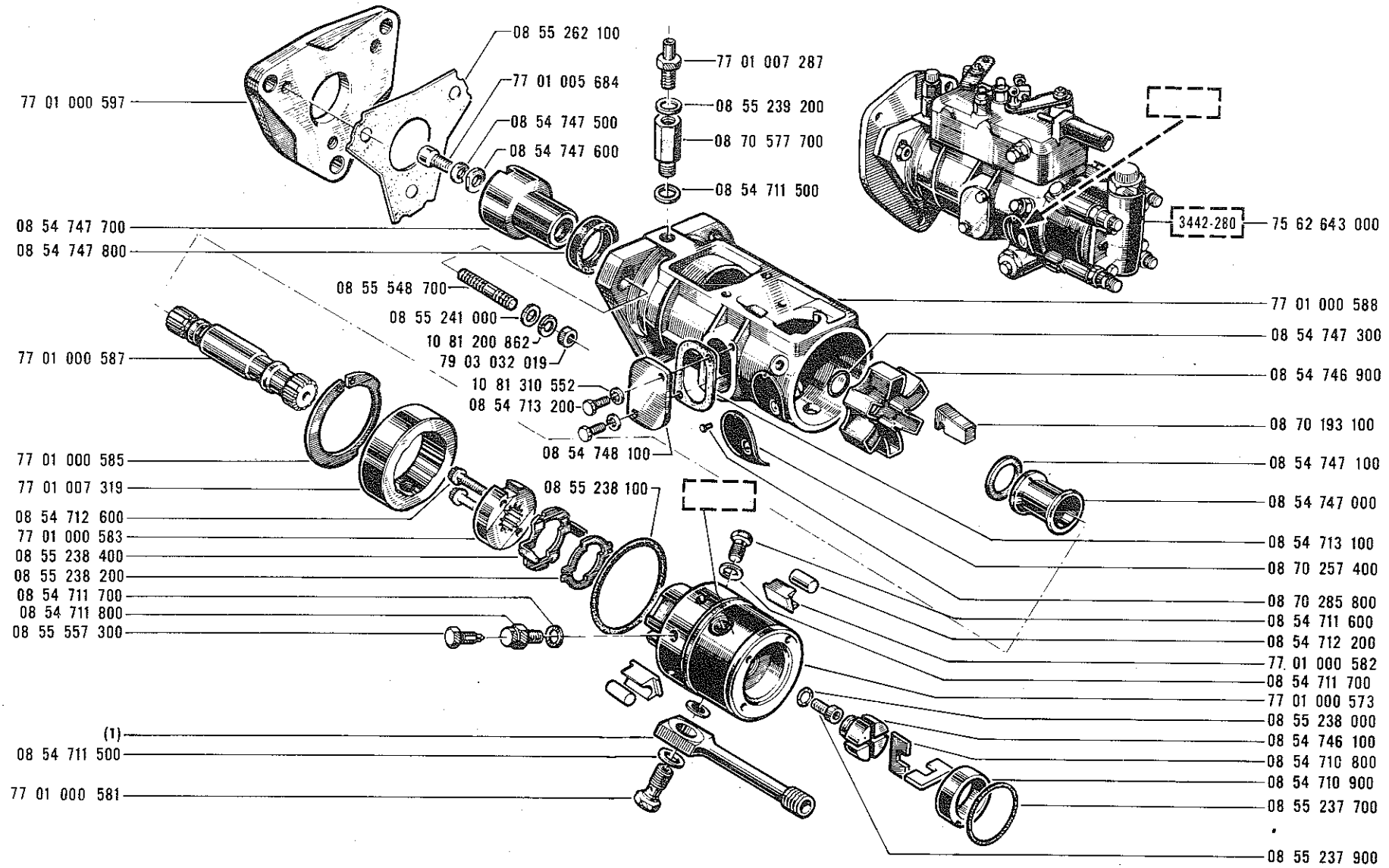
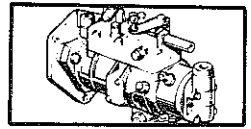

(1)	
77 01 000 579	U & X
77 01 000 580	Y

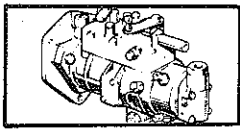

**22.02**  
A P.R. 915

XDP 4.88

**22.02**  
A P.R. 915

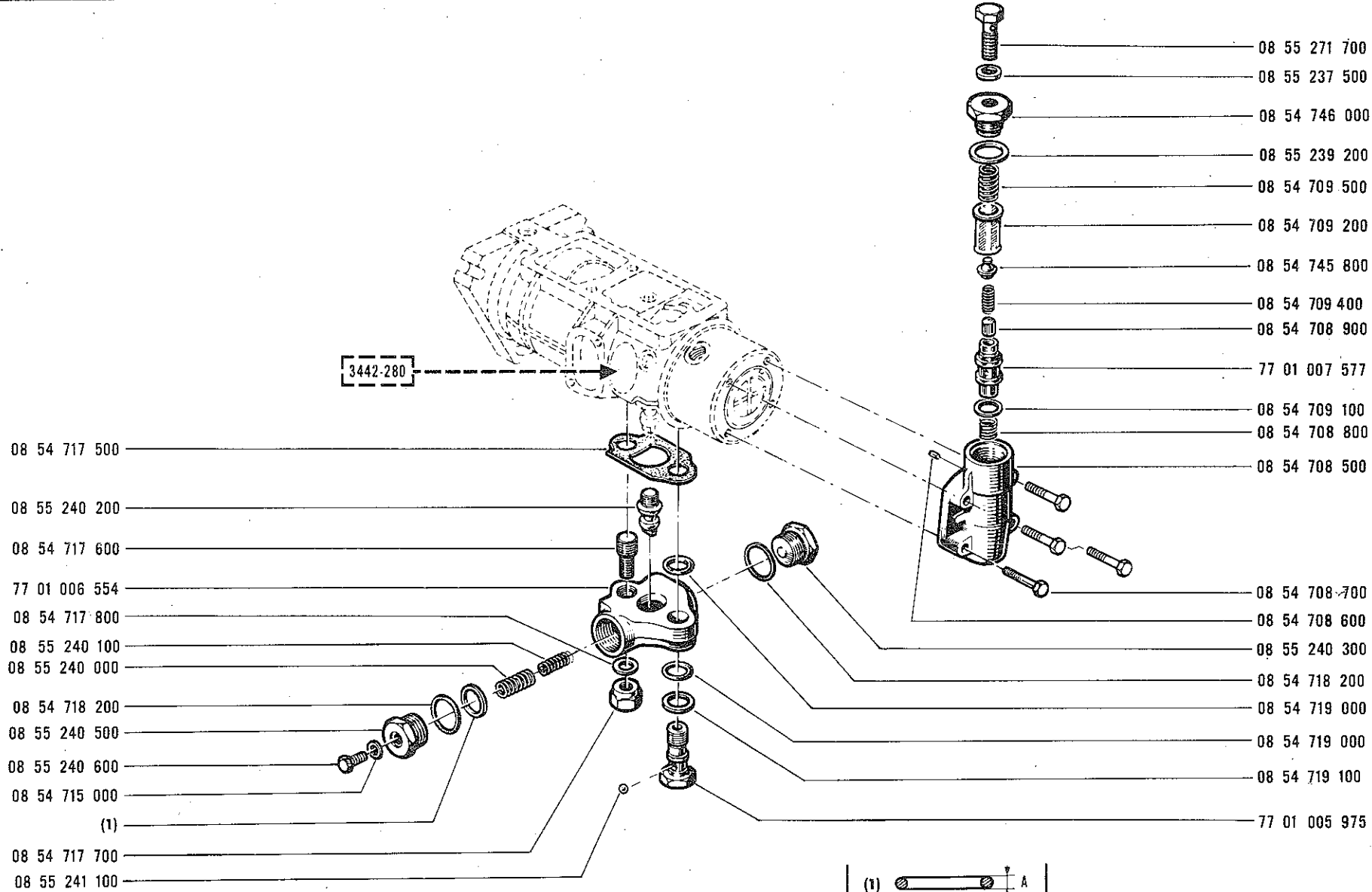
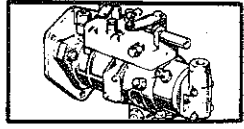

(1)	A
08 55 670 900	A=0,10
08 55 240 700	A=0,20
08 55 240 800	A=0,50
08 55 240 900	A=1,00
08 55 241 000	A=2,00

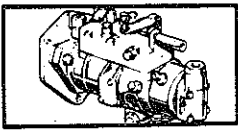

**22.03**

A P.R.915

XDP 4.88

**22.03**

A P.R.915

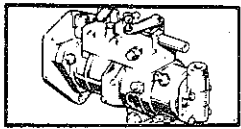

- 77 01 007 289
- 79 02 000 074
- 08 54 749 100
- 77 01 000 595
- 77 01 000 596
- 08 55 550 200
- 08 54 749 200
- 08 54 748 000
- 08 54 716 000
- 08 54 715 700
- 08 55 557 300
- 08 54 717 000
- 08 54 750 900
- 08 55 272 500
- 77 01 007 288
- 08 54 749 600
- 10 81 110 352
- 08 54 749 800
- 08 54 750 700
- 08 54 749 700
- 08 54 748 300
- 08 54 748 400
- 08 54 749 400
- 08 54 749 000
- 08 54 748 600
- 08 54 748 500

- 08 54 751 100
- 08 54 717 200
- 79 02 000 214
- 08 54 717 200
- 10 81 310 552
- 10 81 110 552
- 08 55 239 500
- 08 54 750 400
- 08 54 751 300
- 08 54 717 200
- 08 54 751 200
- 08 54 751 100
- 08 55 272 600
- 77 01 000 594
- 08 54 750 100
- 08 54 750 000
- 08 54 717 000
- 08 54 750 500
- 08 54 749 500
- 08 54 749 300
- 08 55 670 500
- 08 55 670 600 (6-375)
- 08 54 748 800
- 08 54 748 900
- 08 55 239 300

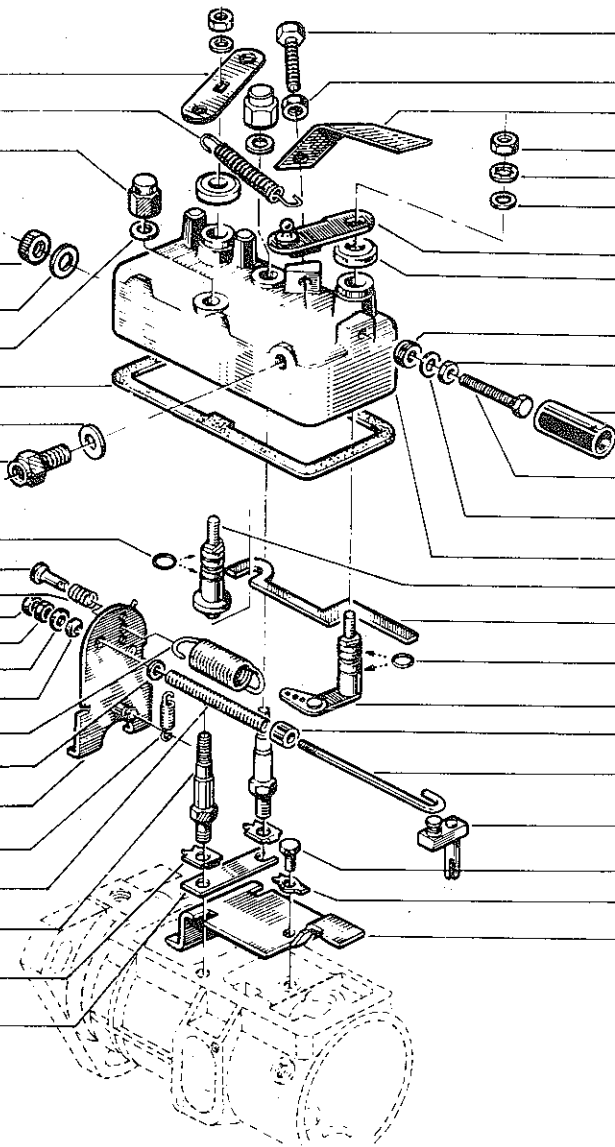

6-375

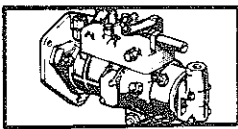

22.10

A P.R.915

XDP 4.90

22.10

A P.R.915

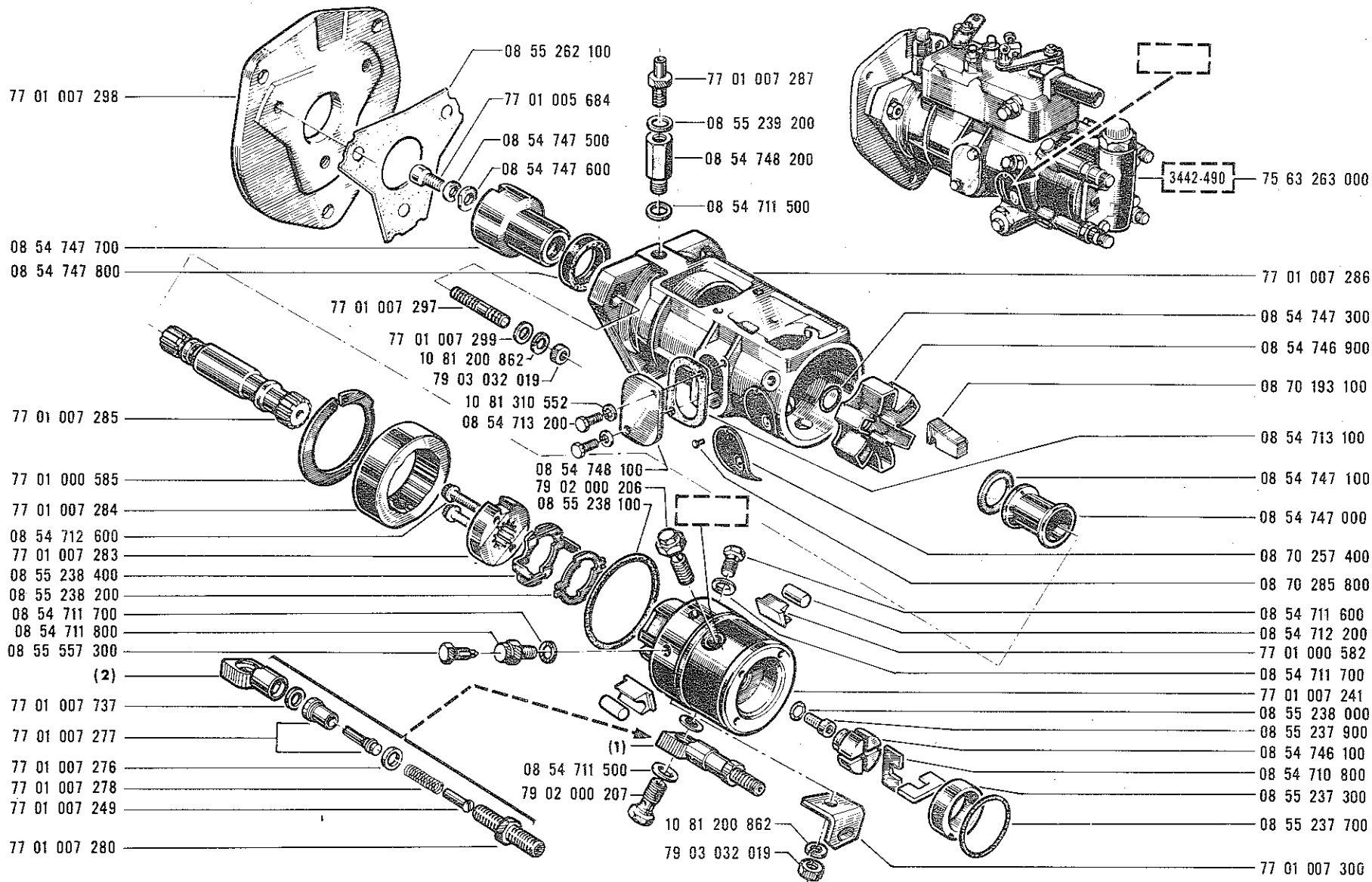
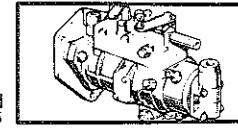

(1)	
79 02 000 733	U & X
79 02 000 734	V
79 02 000 735	W

(2)	
77 01 007 256	79 02 000 733
77 01 007 274	79 02 000 734
77 01 007 275	79 02 000 735



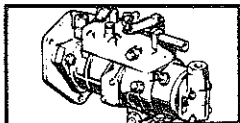

**22.11**

A P.R. 915

XDP 4.90

**22.11**

A P.R. 915

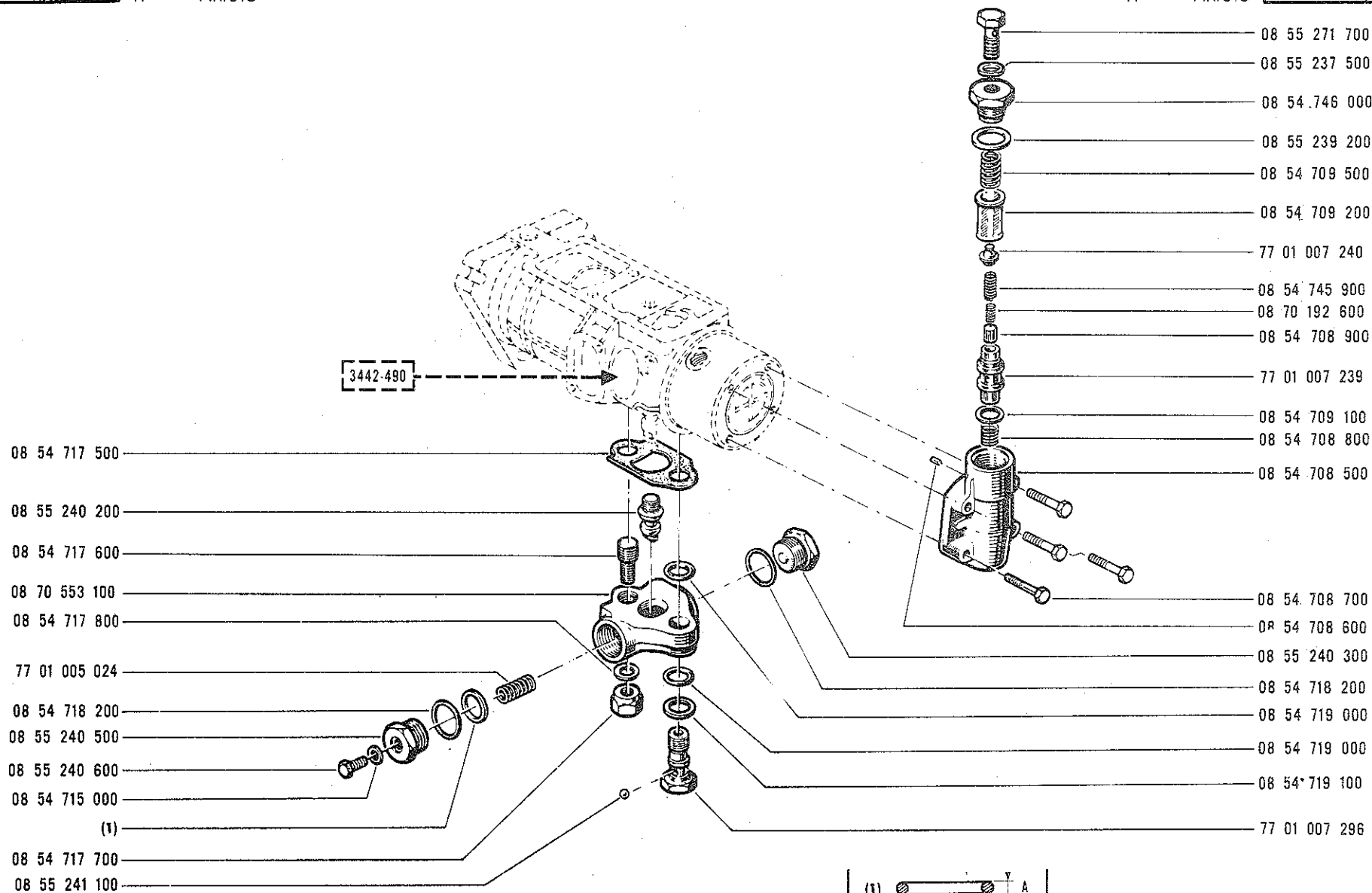

(1)	A
08 55 670 900	A=0,10
08 55 240 700	A=0,20
08 55 240 800	A=0,50
08 55 240 900	A=1,00
08 55 241 000	A=2,00

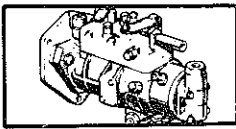

**22.12**

A P.R.915

XDP 4.90

**22.12**

A P.R.915

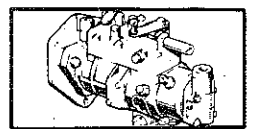

- 77 01 007 289
- 79 02 000 074
- 08 54 749 100
- 77 01 000 595
- 77 01 000 596
- 08 55 550 200
- 08 54 749 200
- 08 54 748 000
- 08 54 716 000
- 08 54 715 700
- 08 55 557 300
- 08 54 717 000
- 08 54 750 900
- 77 01 007 292
- 77 01 007 288
- 08 54 749 600
- 10 81 110 352
- 08 54 749 800
- 77 01 007 291
- 08 54 749 700
- 08 54 748 300
- 08 54 748 400
- 08 54 749 400
- 08 54 749 000
- 08 54 748 600
- 08 54 748 500

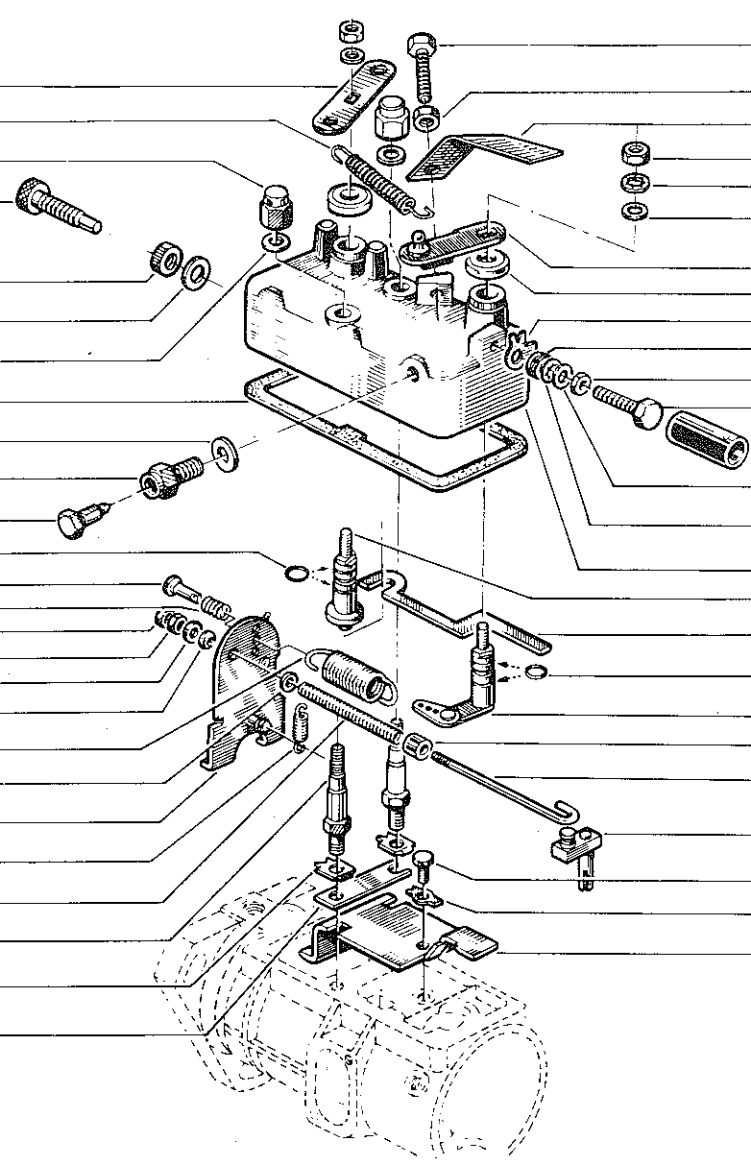

- 08 54 751 100
- 08 54 717 200
- 79 02 000 214
- 08 54 717 200
- 10 81 310 552
- 10 81 110 552
- 08 55 239 500
- 08 54 750 400
- 77 01 007 294
- 08 54 751 300
- 08 54 717 200
- 08 54 751 100
- 77 01 007 293
- 08 55 272 600
- 10 81 310 552
- 77 01 000 594
- 08 54 750 100
- 08 54 750 000
- 08 54 717 000
- 08 54 750 500
- 08 54 749 500
- 08 54 749 300
- 08 55 239 400
- 08 70 556 300 (6-375)
- 08 54 748 800
- 08 54 748 900
- 08 55 239 300

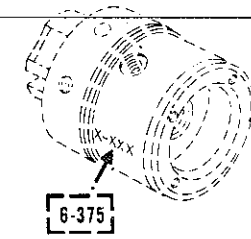

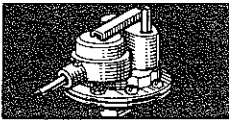

**22.30**

A P.R.915

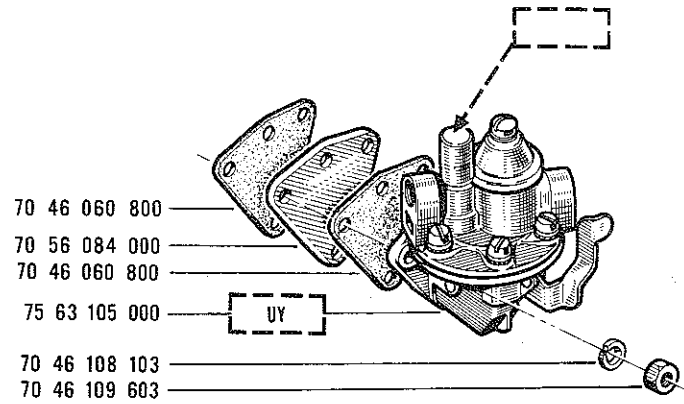

UY

77 01 008 036

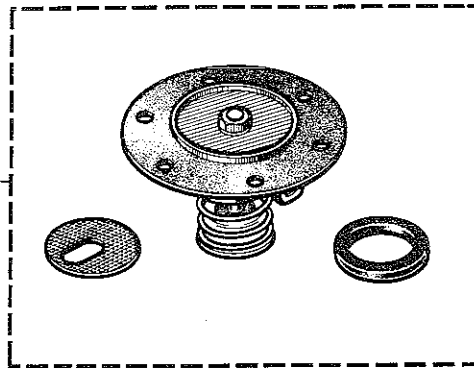

**22.30**

A P.R.915

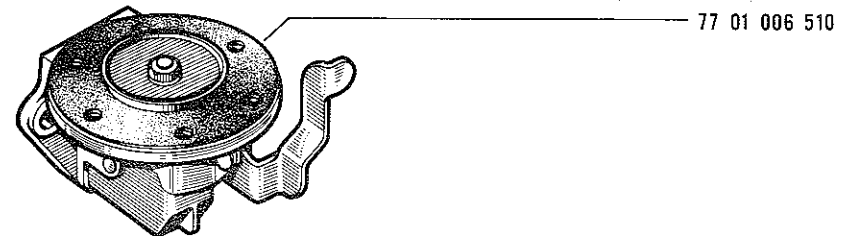
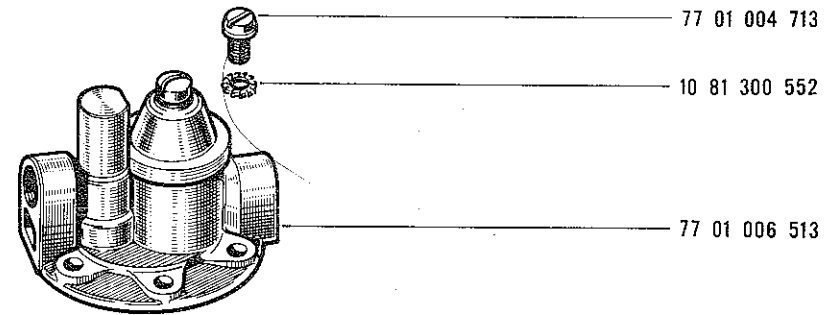
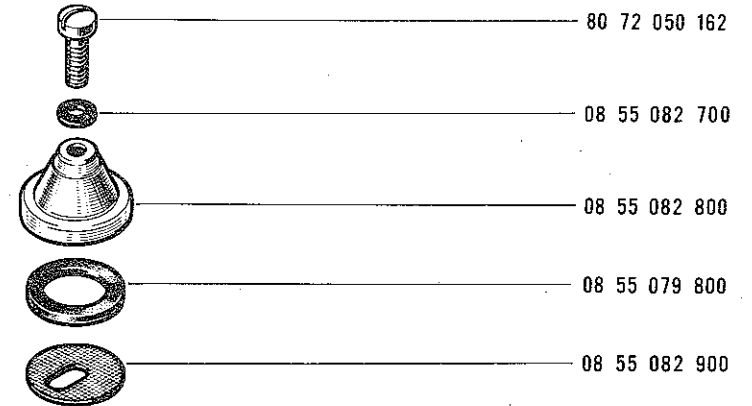
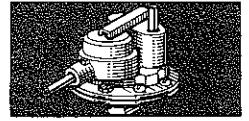

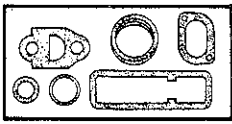

**22.35**

A P.R.915

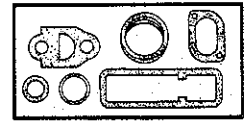

**22.35**

A P.R.915

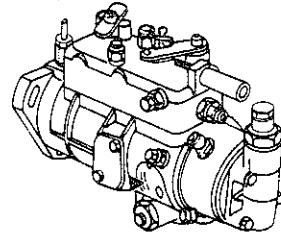

08 70 441 500

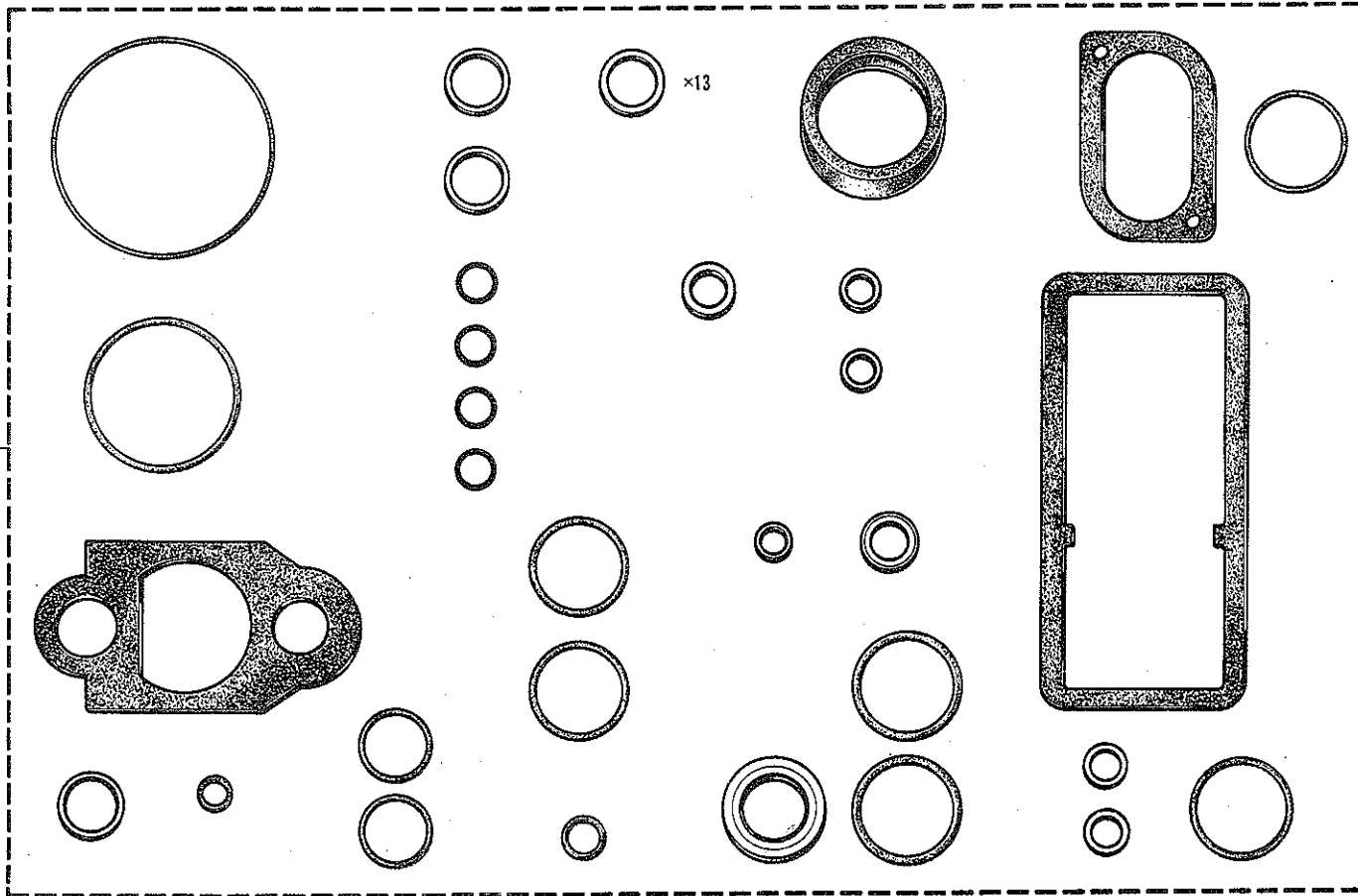

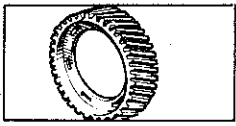

**22.40**  
A P.R.915

**22.40**  
A P.R.915

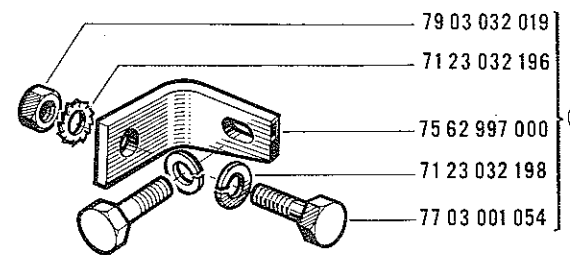
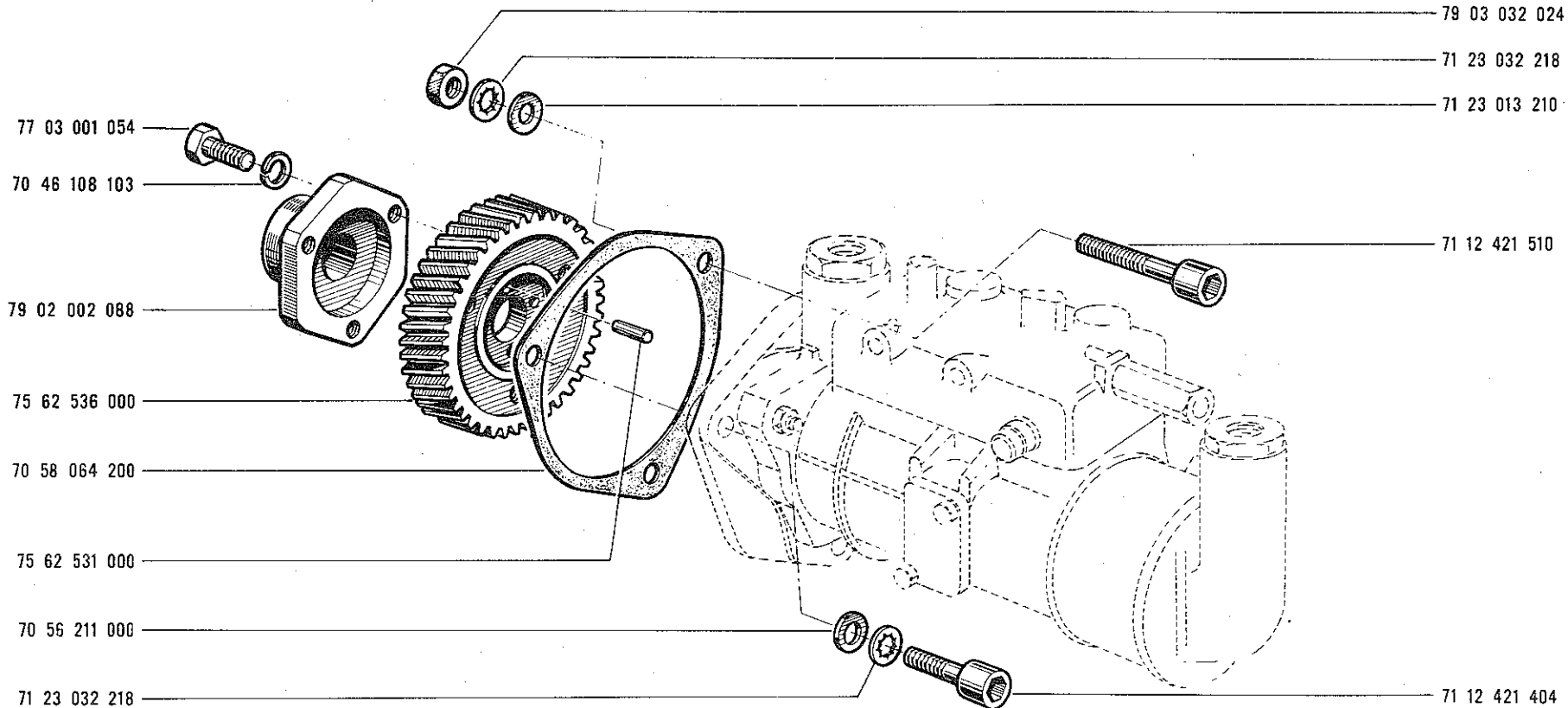
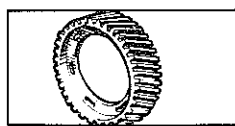

(XDP 4.90)

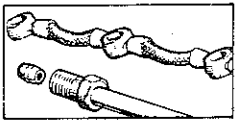

**23.01**

A P.R.915

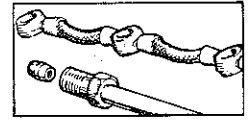

**23.01**

A P.R.915

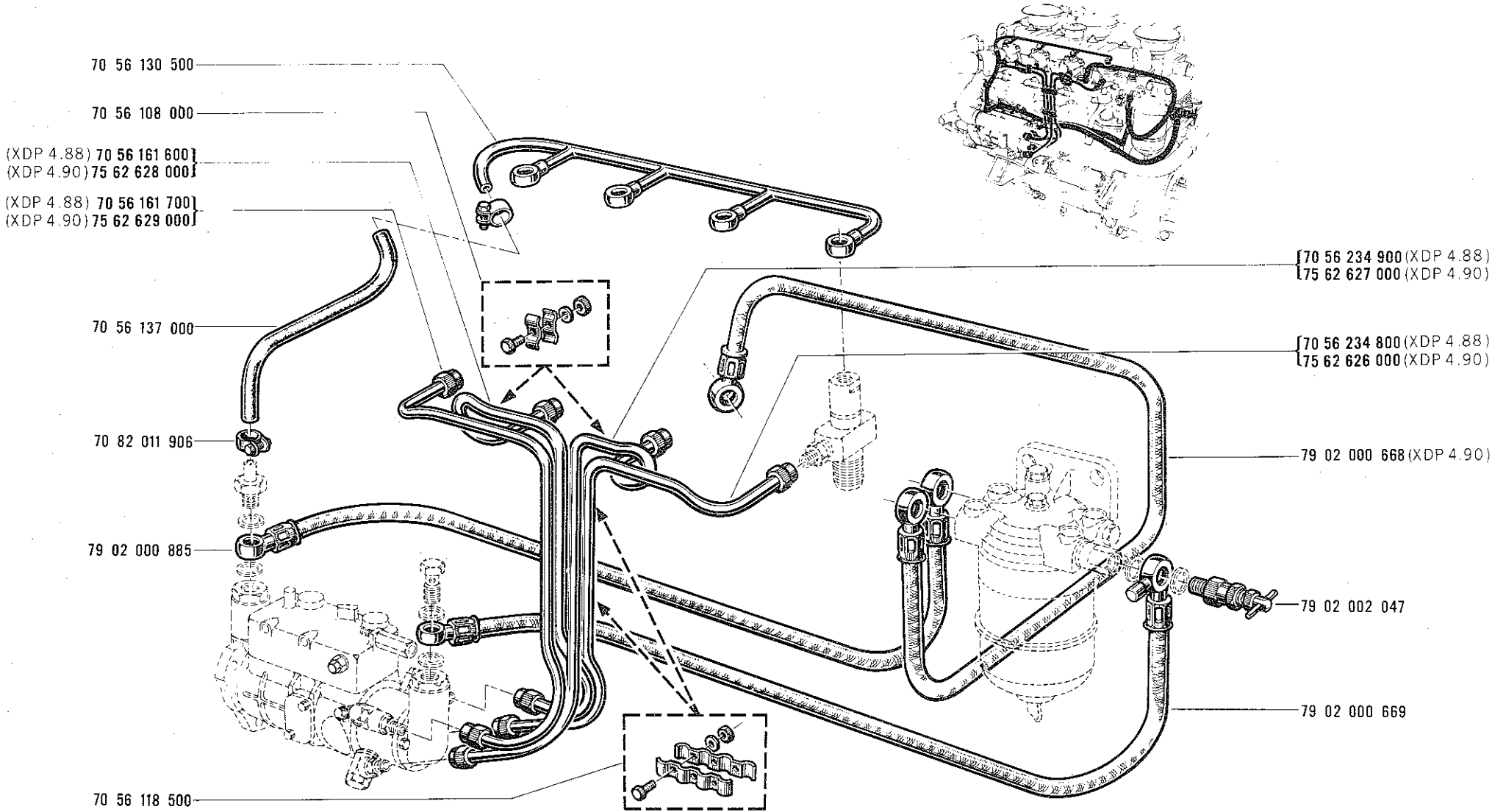

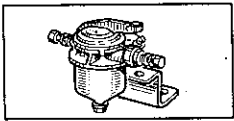

**23.15**

A P.R. 915

**23.15**

A P.R. 915

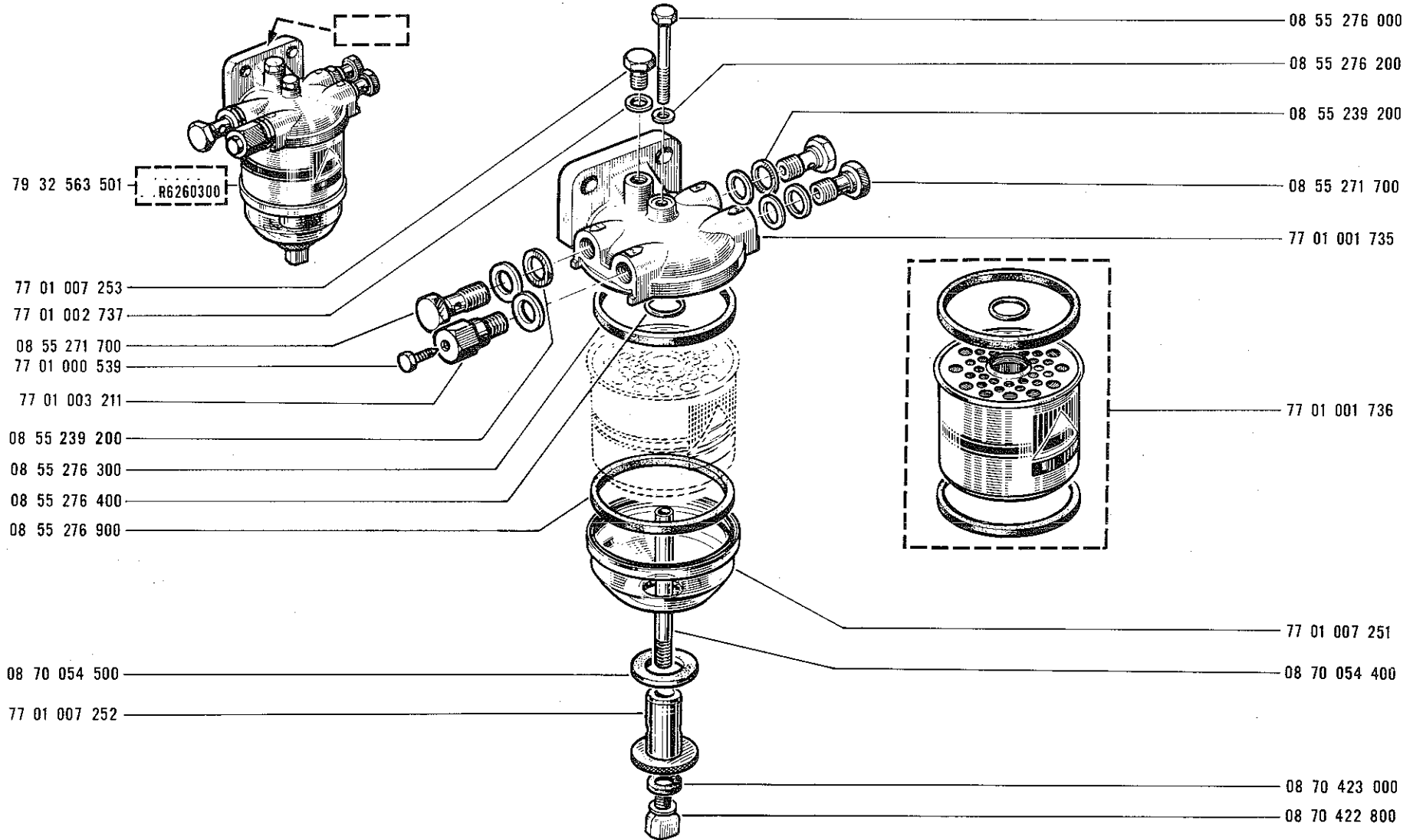
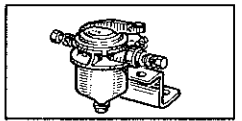

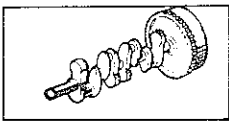

**24.01**

A P.R.915

**24.01**

A P.R.915

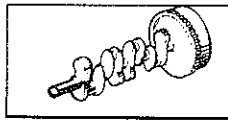

{ (XDP 4.88) 75 81 420 000  
(XDP 4.90) 75 63 209 100 }

{ (XDP 4.88) 75 81 421 000  
(XDP 4.90) 75 63 093 000 }

{ (XDP 4.88) 70 58 142 204  
(XDP 4.90) 75 62 377 000 }

(XDP 4.88) { [A=28] 70 56 082 800  
[A=28,05] 70 56 112 600  
[A=28,10] 70 56 112 700 }

(XDP 4.90) { [A=28] 70 58 154 300  
[A=28,05] 75 62 896 000  
[A=28,10] 75 62 897 000 }

71 23 121 370

{ [B=31] 70 58 055 400  
[B=31,30] 70 56 112 800 }

75 72 101 000

75 62 693 000

(1)

07 03 515 700

70 56 168 800

75 80 496 100

70 46 122 500

70 56 207 600

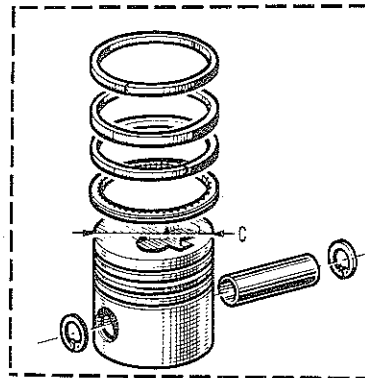

{ 75 71 291 000 [C=87,90]  
75 71 292 000 [C=87,94] } (XDP 4.88)  
{ 79 02 000 358 [C=89,90]  
79 02 000 359 [C=89,94] } (XDP 4.90)

70 58 152 400

{ 70 46 014 510 (XDP 4.88)  
78 06 045 000 (XDP 4.90) }

70 46 361 200

{ 70 46 816 500 (XDP 4.88)  
75 62 853 000 (XDP 4.90) }

{ 75 70 207 000 (XDP 4.88)  
79 02 000 362 (XDP 4.90) }

{ 70 56 100 800 (XDP 4.88)  
75 81 721 000 (XDP 4.90) }

{ 70 56 178 600 (XDP 4.88)  
75 62 844 000 (XDP 4.90) }

(1)

75 71 297 000	g=901/930
75 71 298 000	g=931/980
75 71 299 000	g=981/1030



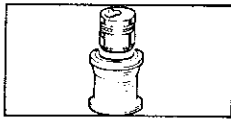

**24.05**

A P.R. 915

**24.05**

A P.R. 915

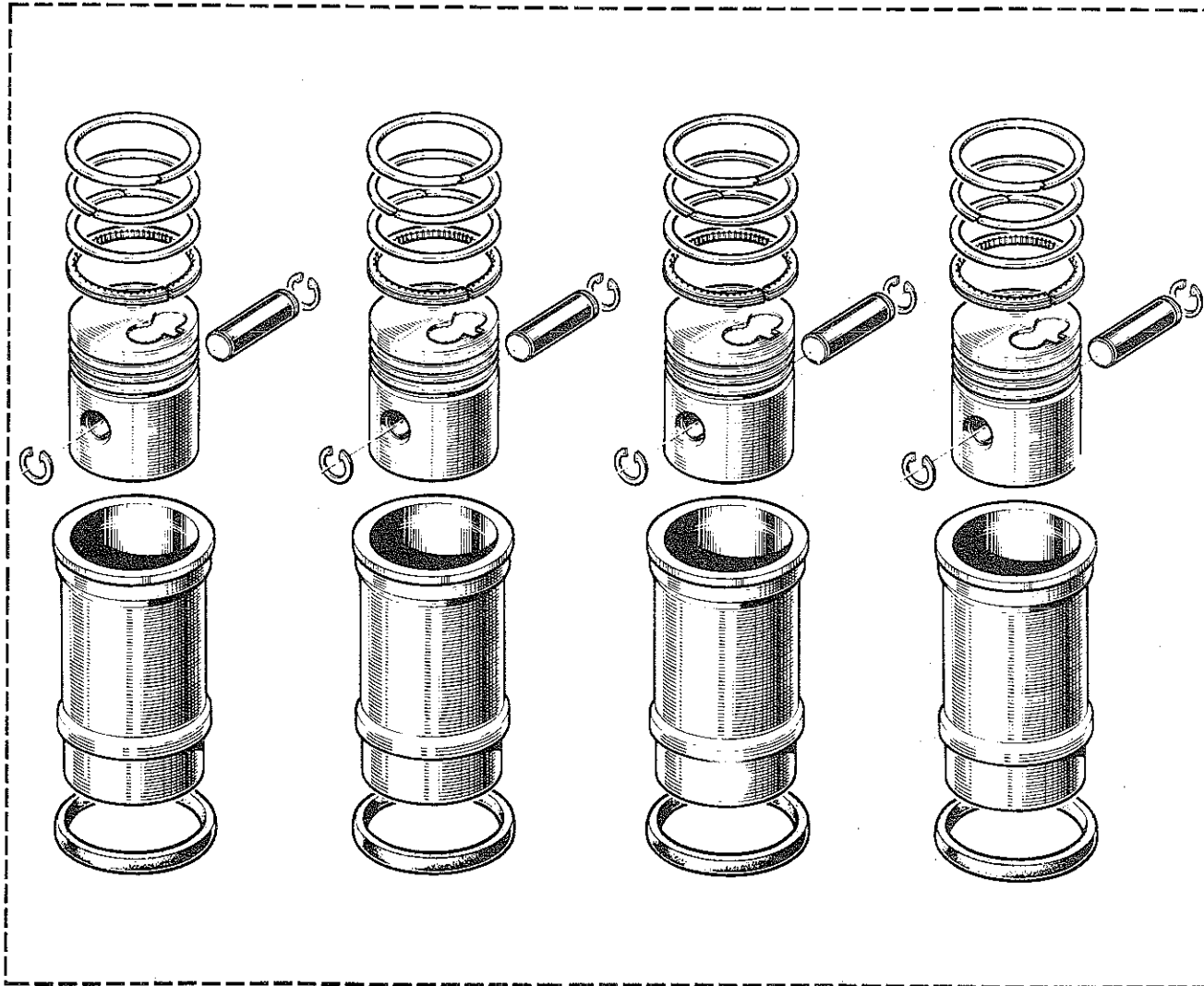
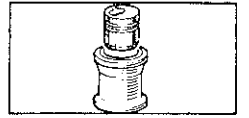

[79 02 000 004 (XDP 4.88)  
79 02 000 361 (XDP 4.90)]

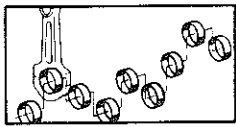

**24.10**

A P.R. 915

**24.10**

A P.R. 915

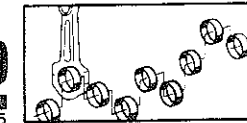

[A=49,984] 70 58 055 900  
 [A=49,884] 70 56 115 400  
 [A=49,484] 70 56 115 500  
 [A=49,184] 70 56 115 600

[A=55] 75 70 220 000  
 [A=54,694] 75 70 221 000  
 [A=54,494] 75 70 222 000  
 [A=54,194] 75 70 223 000

[A=55] 75 70 195 000  
 [A=54,694] 75 70 198 000  
 [A=54,494] 75 70 199 000  
 [A=54,194] 75 70 200 000

[75 70 195 000 (A=55)  
 75 70 198 000 (A=54,694)  
 75 70 199 000 (A=54,494)  
 75 70 200 000 (A=54,194)

[75 70 220 000 (A=55)  
 75 70 221 000 (A=54,694)  
 75 70 222 000 (A=54,494)  
 75 70 223 000 (A=54,194)

[75 70 195 000 (A=55)  
 75 70 198 000 (A=54,694)  
 75 70 199 000 (A=54,494)  
 75 70 200 000 (A=54,194)

[79 02 000 026 (B=2,30)  
 79 02 000 027 (B=2,50)

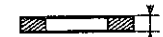
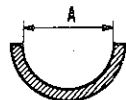

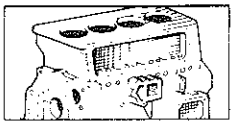

# 24.15

A P.R.915

# 24.15

A P.R.915

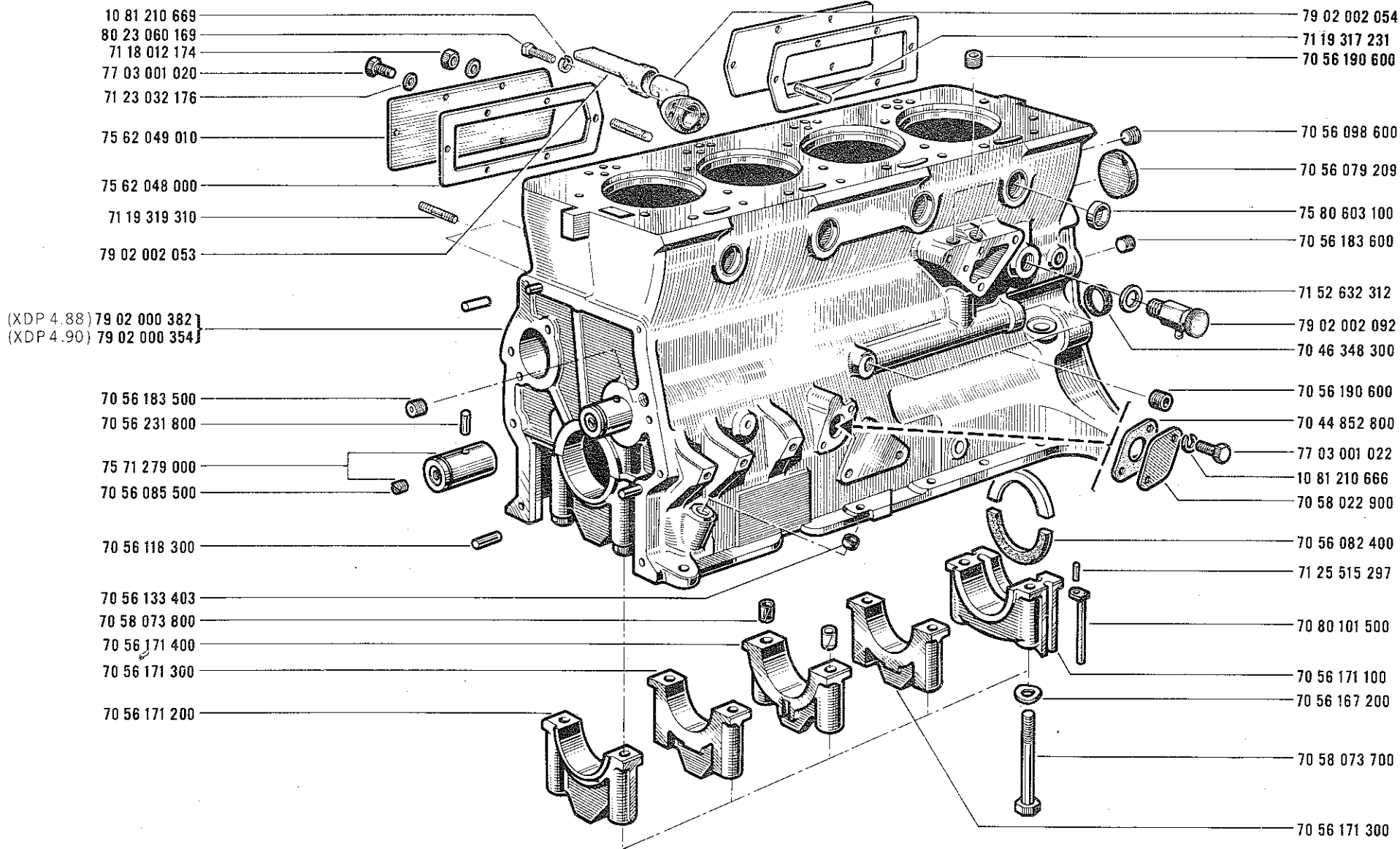
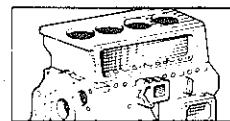

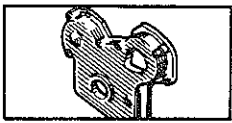

**24.20**

A P.R.915

**24.20**

A P.R.915

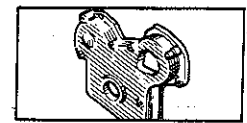

77 03 001 038



77 03 001 044



71 23 032 184

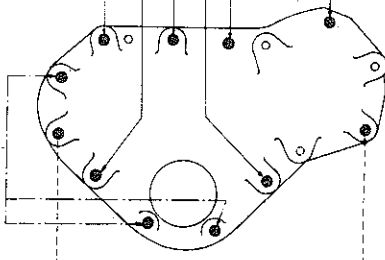

79 03 032 013



77 03 001 043



70 57 396 600

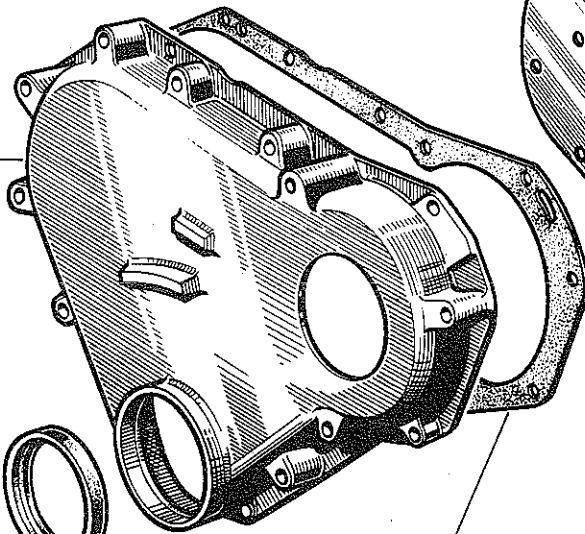

70 56 178 900



70 58 122 700

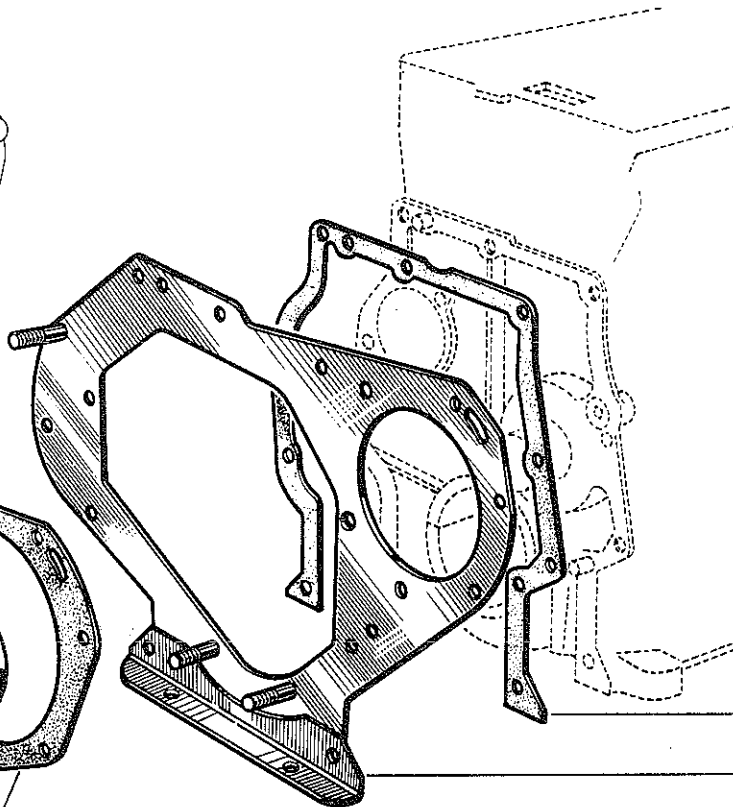

70 58 122 000

75 80 745 200



77 03 001 037



71 11 218 260



77 03 001 038

71 23 032 184

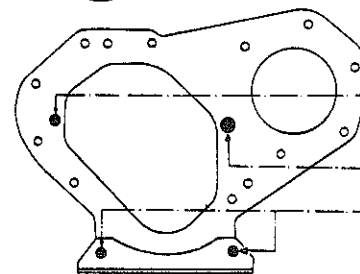

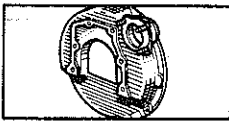

**24.25**

A P.R. 915

**24.25**

A P.R. 915

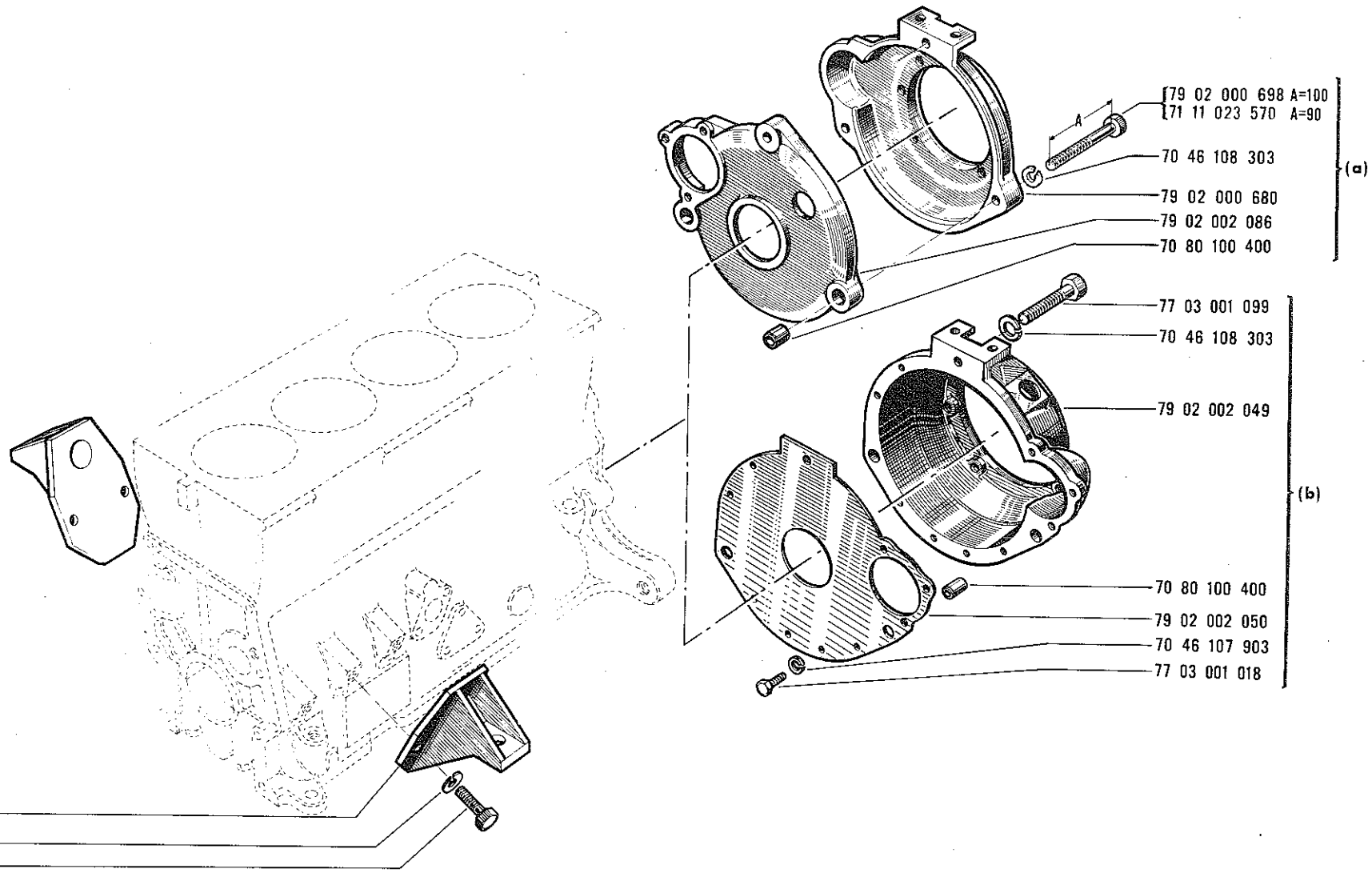
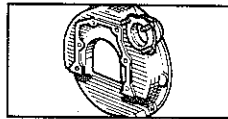

(a) (XDP 4.88)

(b) (XDP 4.90)

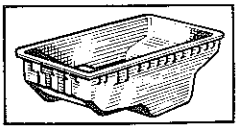

**24.30**

A P.R. 915

**24.30**

A P.R. 915

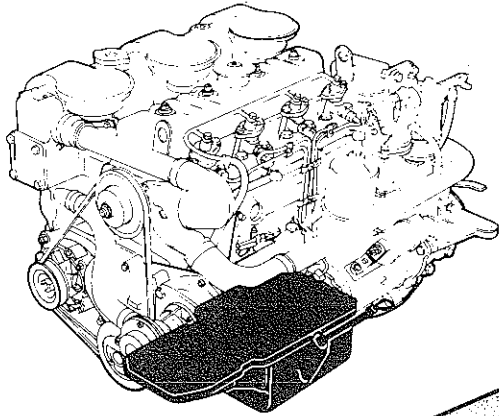
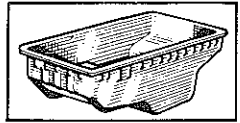

77 03 001 038

70 58 058 000

79 32 563 462

70 46 108 003

79 03 032 013

77 03 001 038

79 42 000 014

70 56 079 800

79 32 563 470

71 52 632 312

70 46 000 300

70 46 312 603

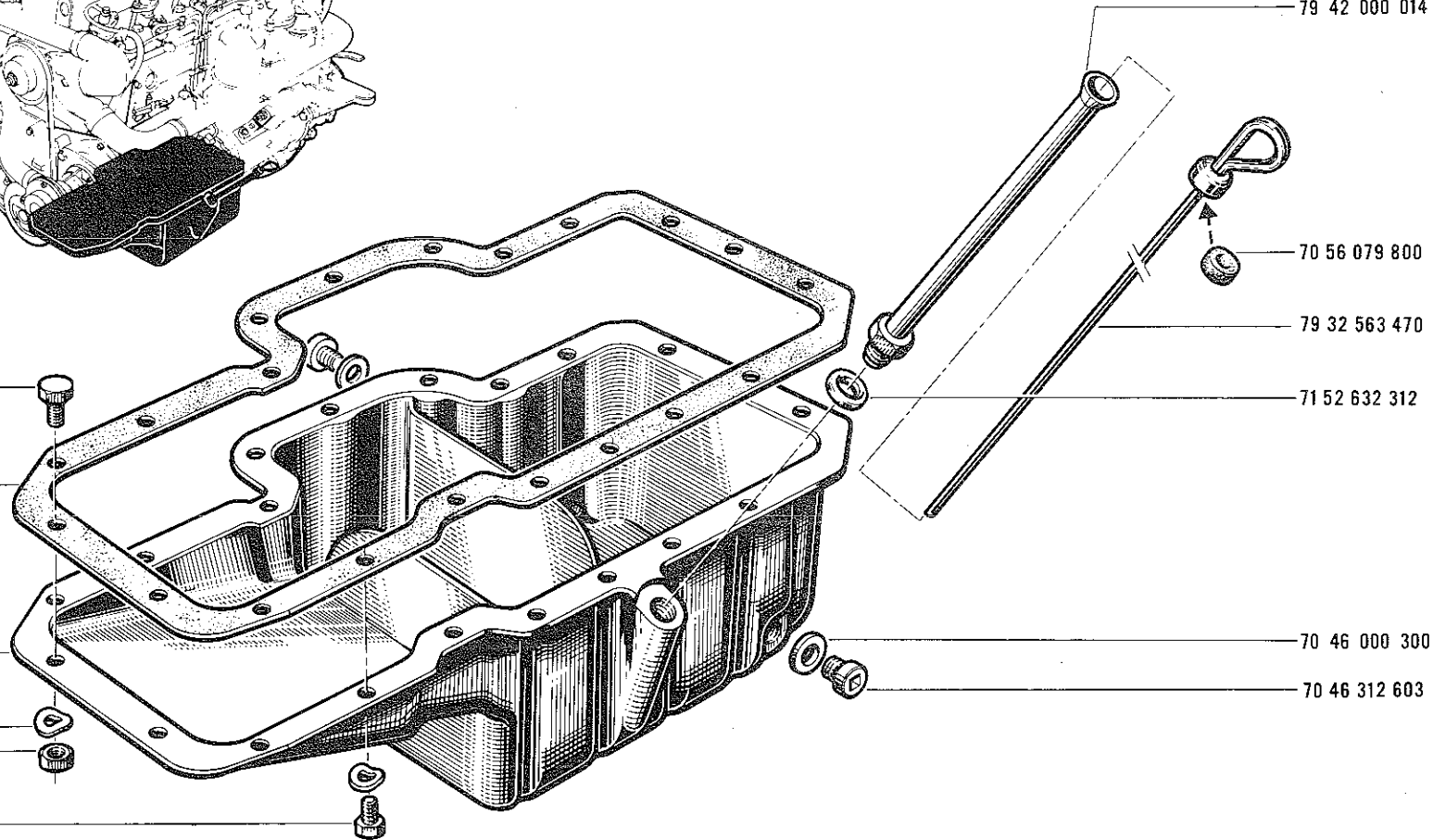

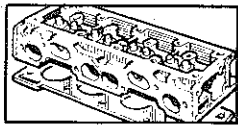

**25.01**

A P.R.915

**25.01**

A P.R.915

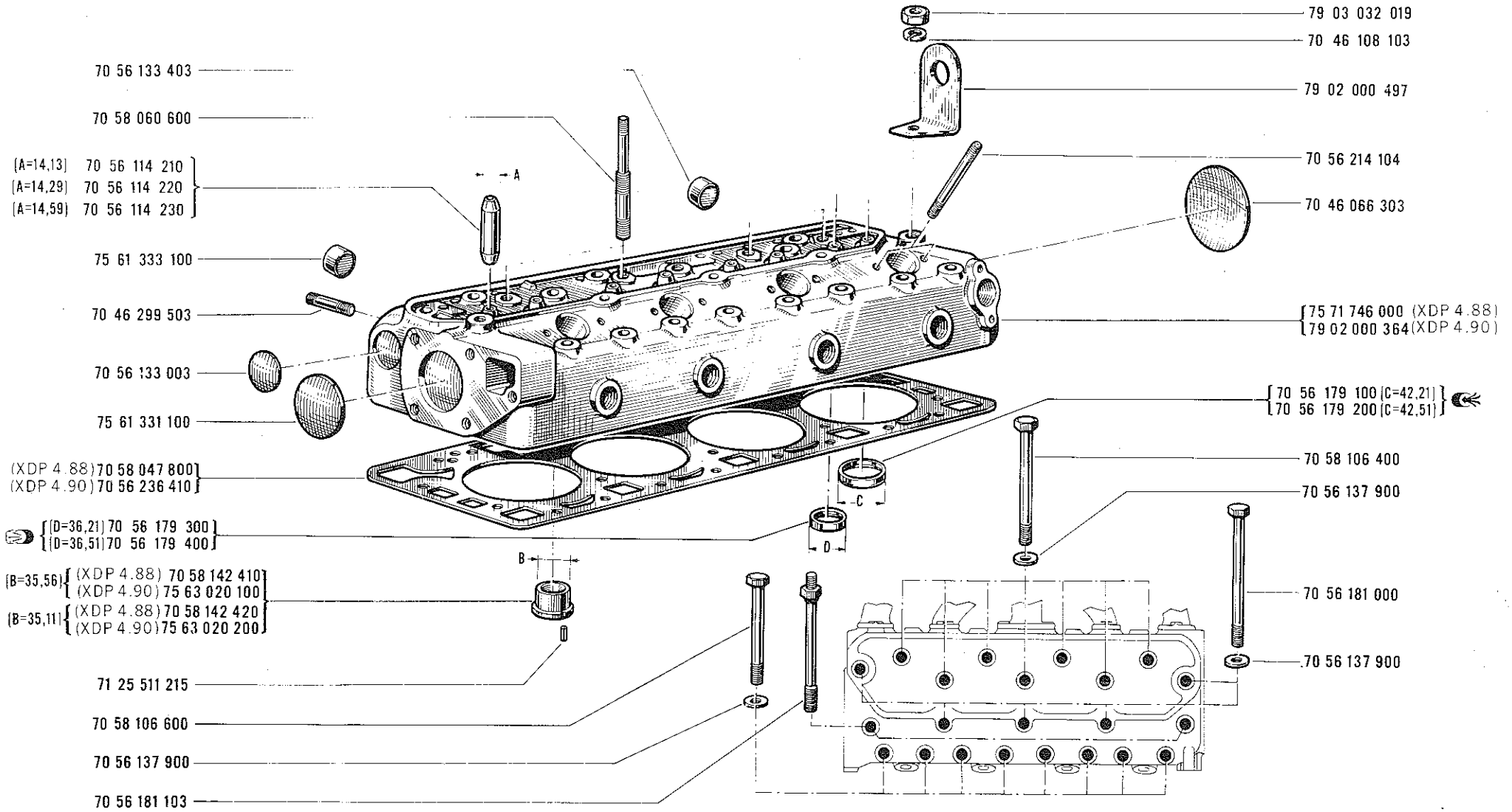
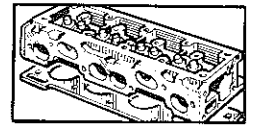

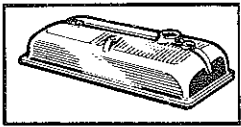

**25.10**  
A P.R. 915

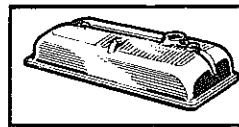

**25.10**  
A P.R. 915

08 54 328 900  
70 46 285 003  
75 62 968 000

70 46 724 300  
70 46 098 910  
70 58 156 905  
70 58 157 000

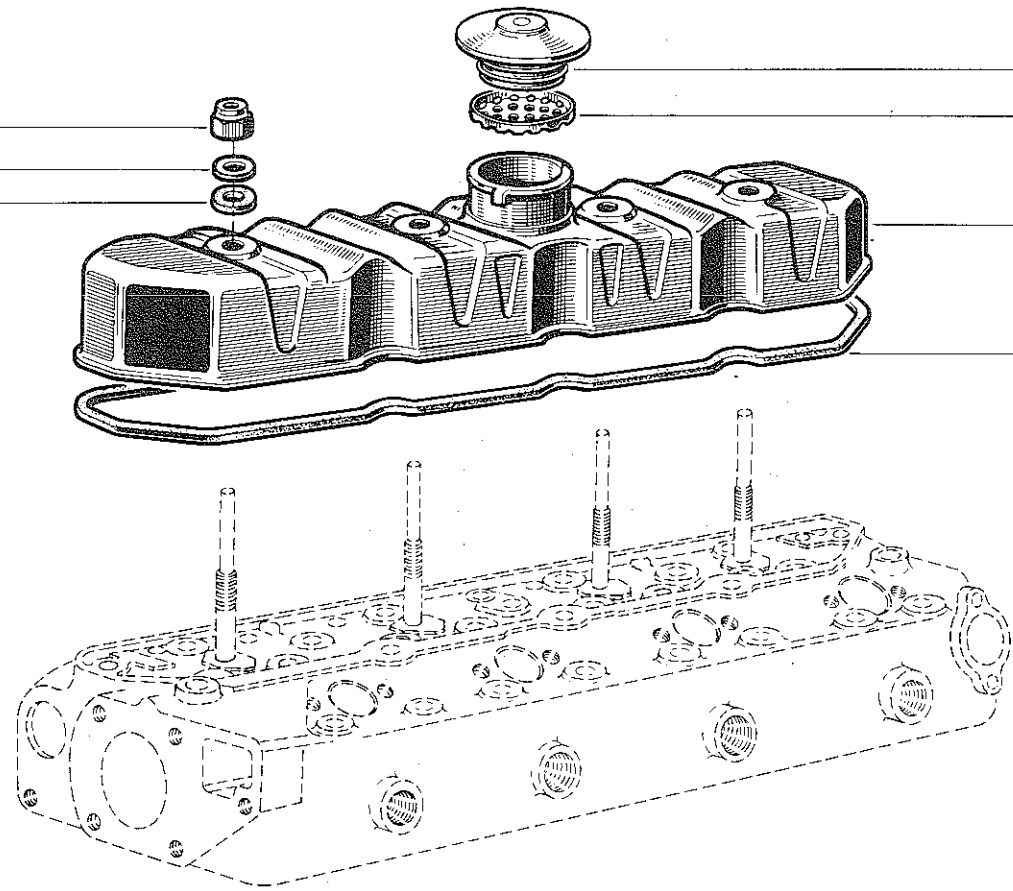



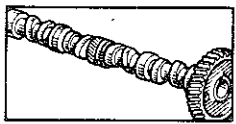

**25.20**

A P.R. 915

**25.20**

A P.R. 915

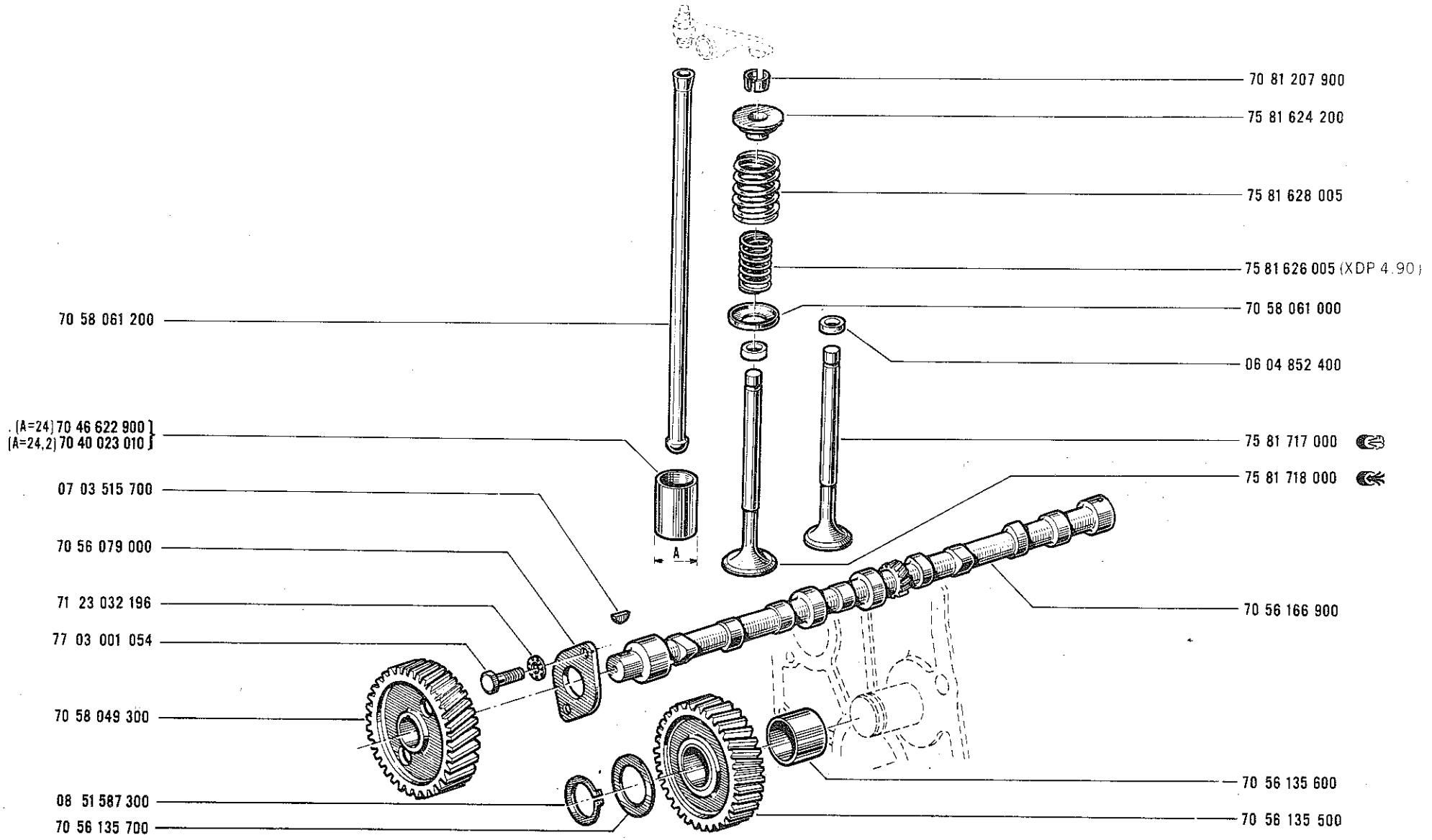
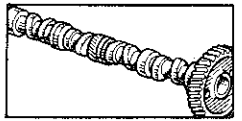

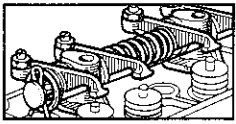

**25.25**

A P.R.915

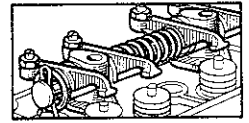

**25.25**

A P.R.915

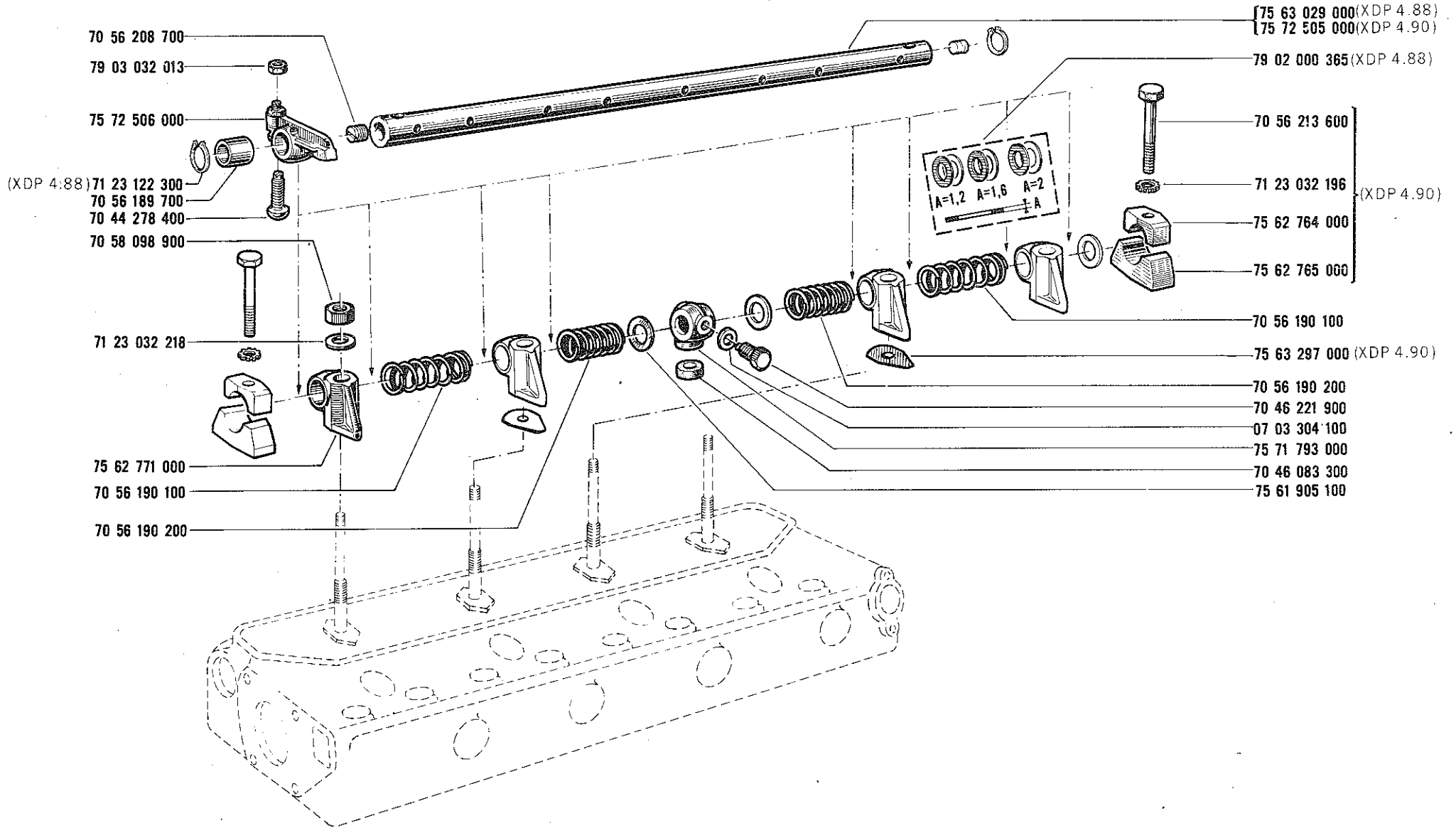

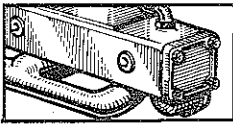

**25.30**

A P.R. 915

**25.30**

A P.R. 915

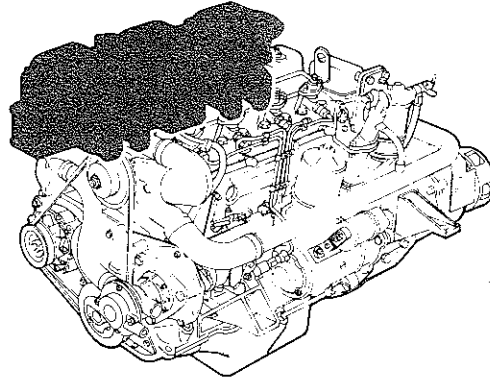
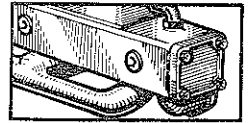

79 02 002 052

79 02 000 888

79 02 000 566

79 02 000 587

79 02 000 897

79 02 000 612

79 02 000 595

79 02 000 895

79 02 002 040

77 01 007 930

77 01 007 929

77 01 007 928

79 02 000 896

79 02 000 897

79 02 000 884

79 02 000 883

79 02 000 884

79 02 000 602

79 02 000 546

79 02 000 611

79 02 000 607

79 02 000 883

79 02 000 884

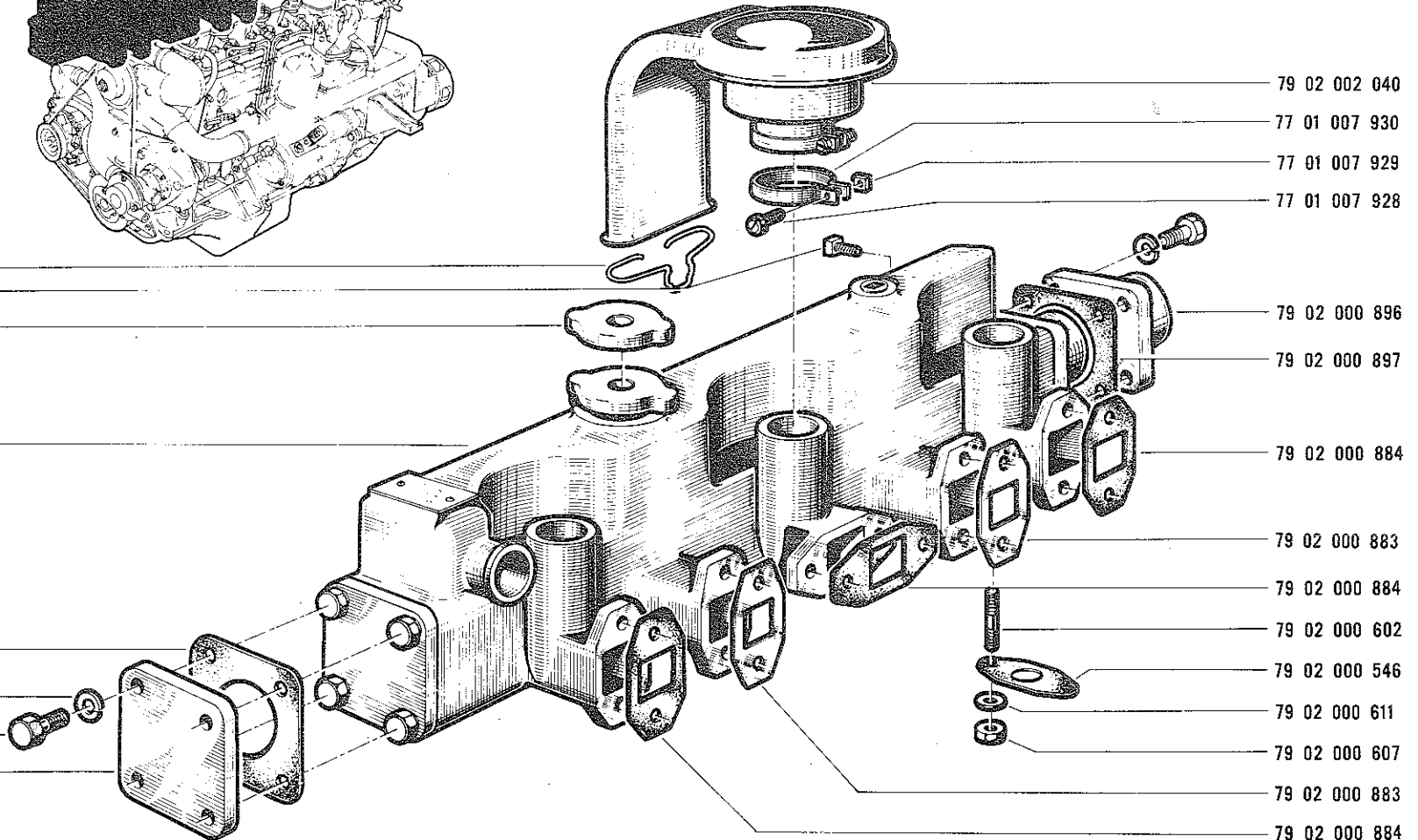

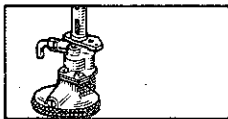

**26.01**

A P.R.915

**26.01**

A P.R.915

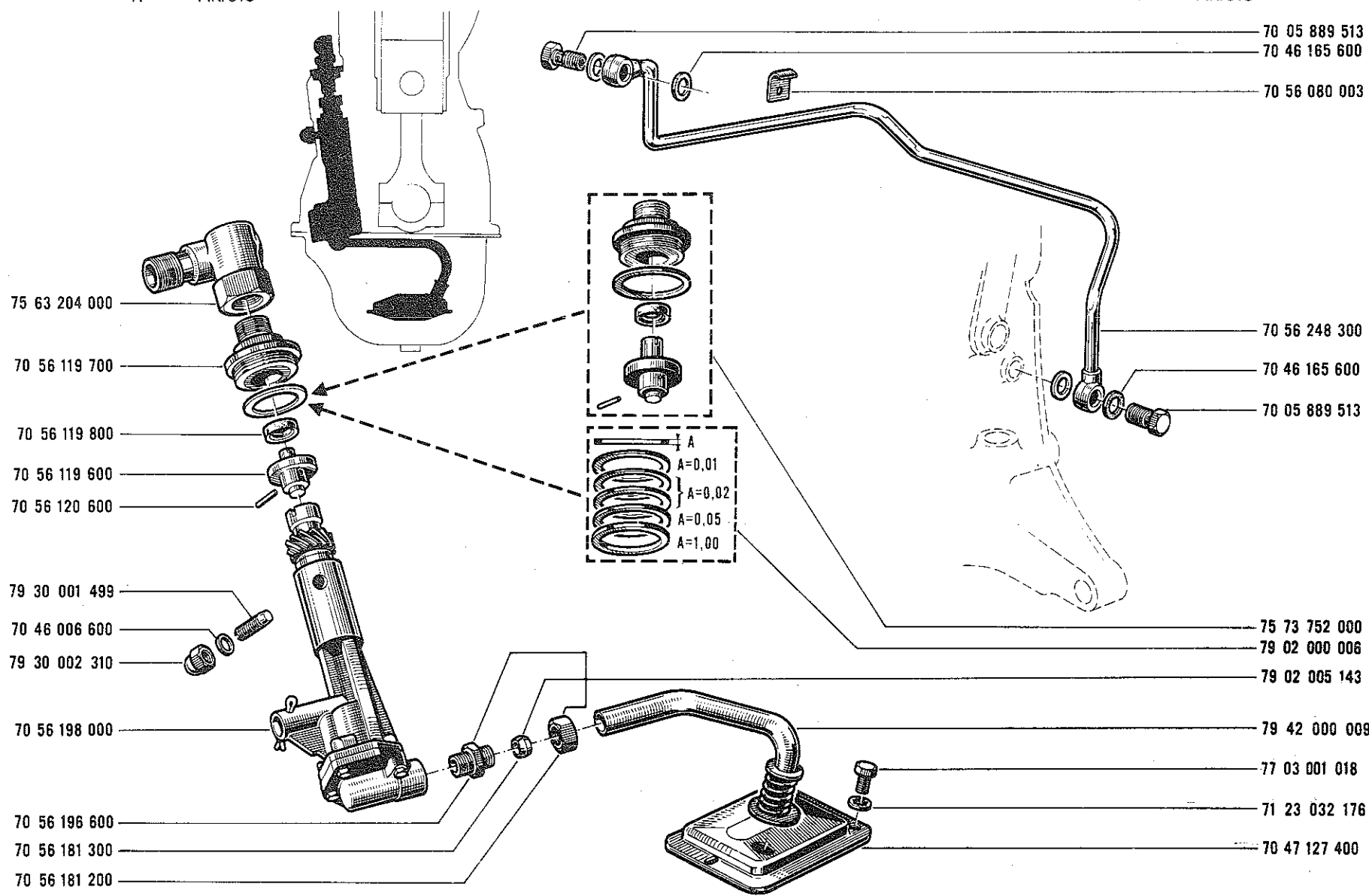
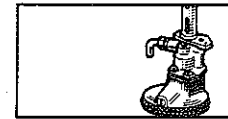

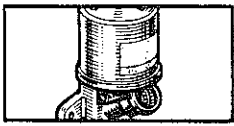

**26.05**

A P.R.915

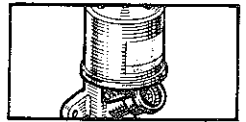

**26.05**

A P.R.915

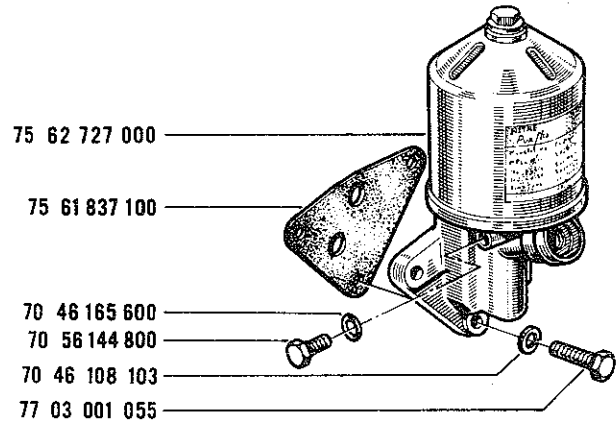

- 79 02 000 012
- 79 02 000 011
- 77 01 000 790

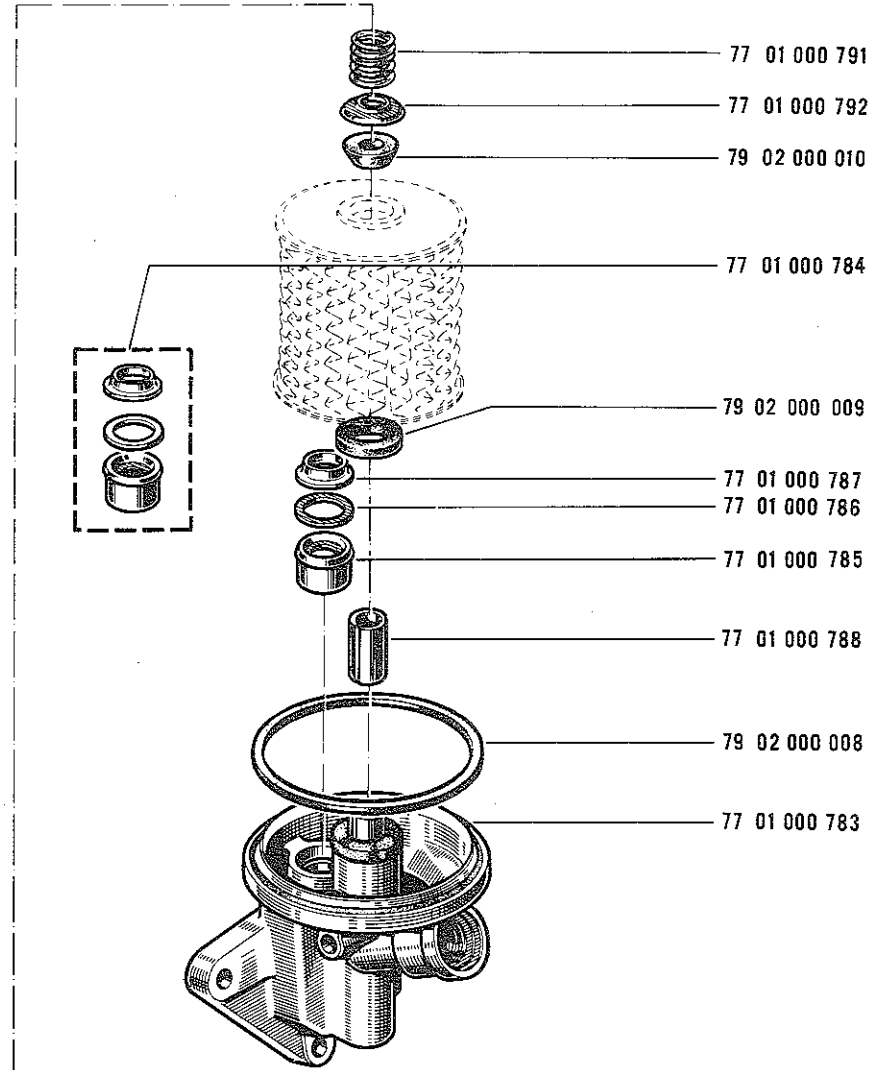
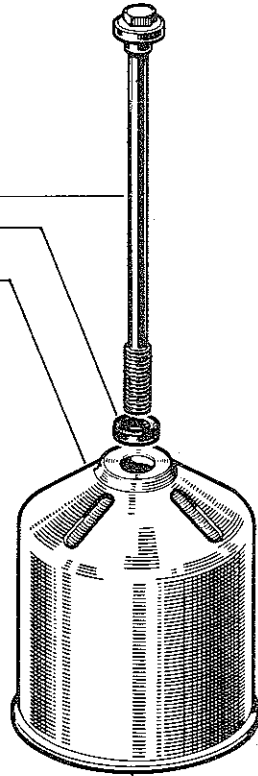
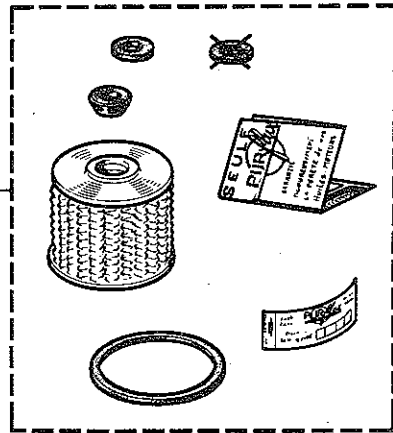

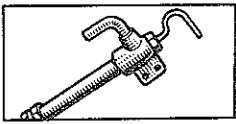

**26.15**

A P.R.915

**26.15**

A P.R.915

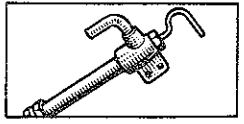

79 02 002 003

79 02 000 584

70 46 108 003

79 02 002 064

79 02 002 062

79 02 002 063

77 01 007 624

79 02 002 072

79 02 002 066

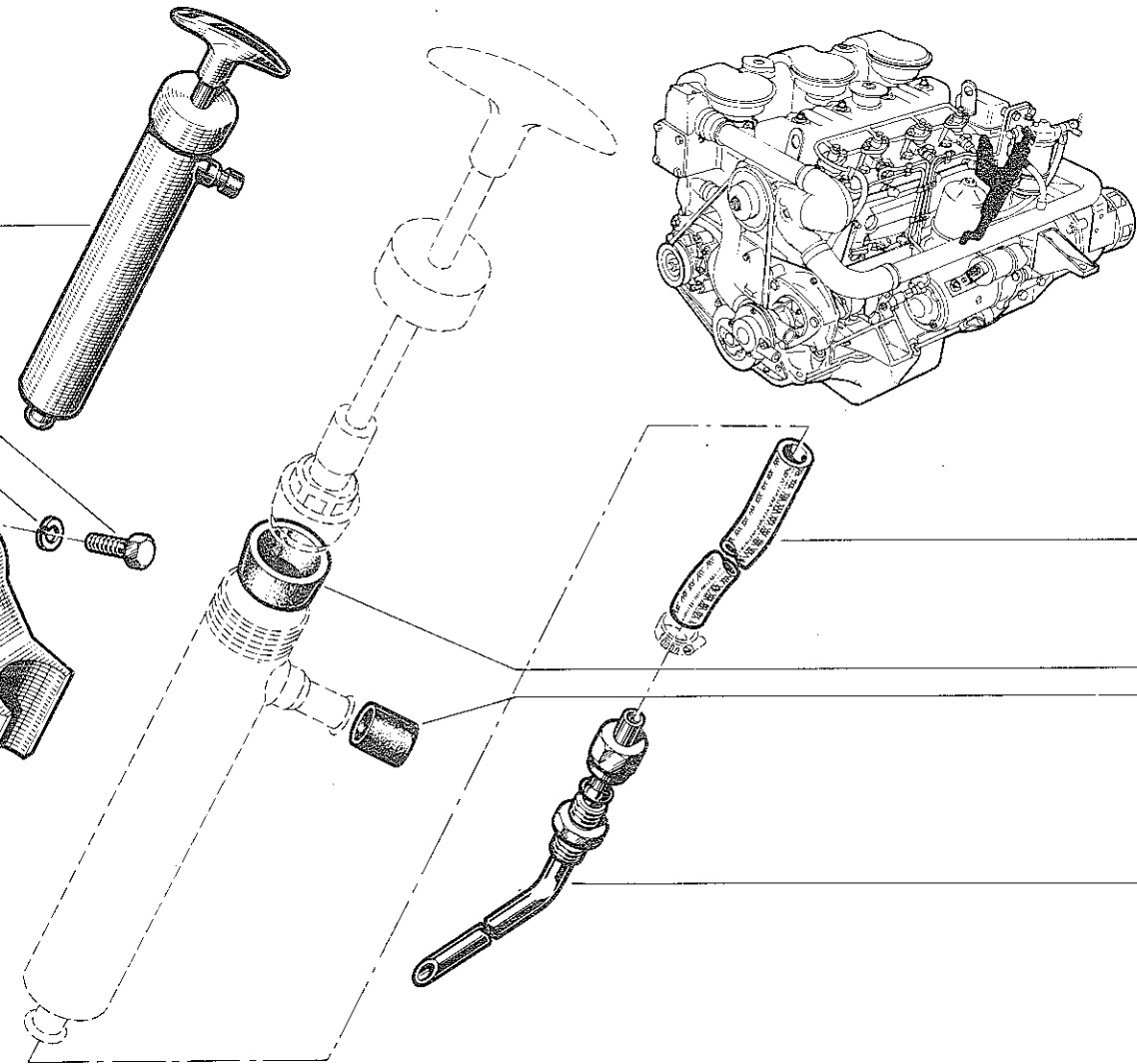

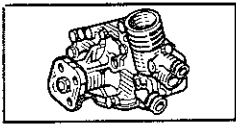

**27.01**  
A P.R. 915

**27.01**  
A P.R. 915

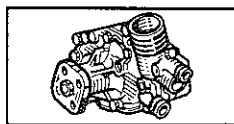

(XDP 4.88)79 02 000 651  
(XDP 4.90)79 02 000 195

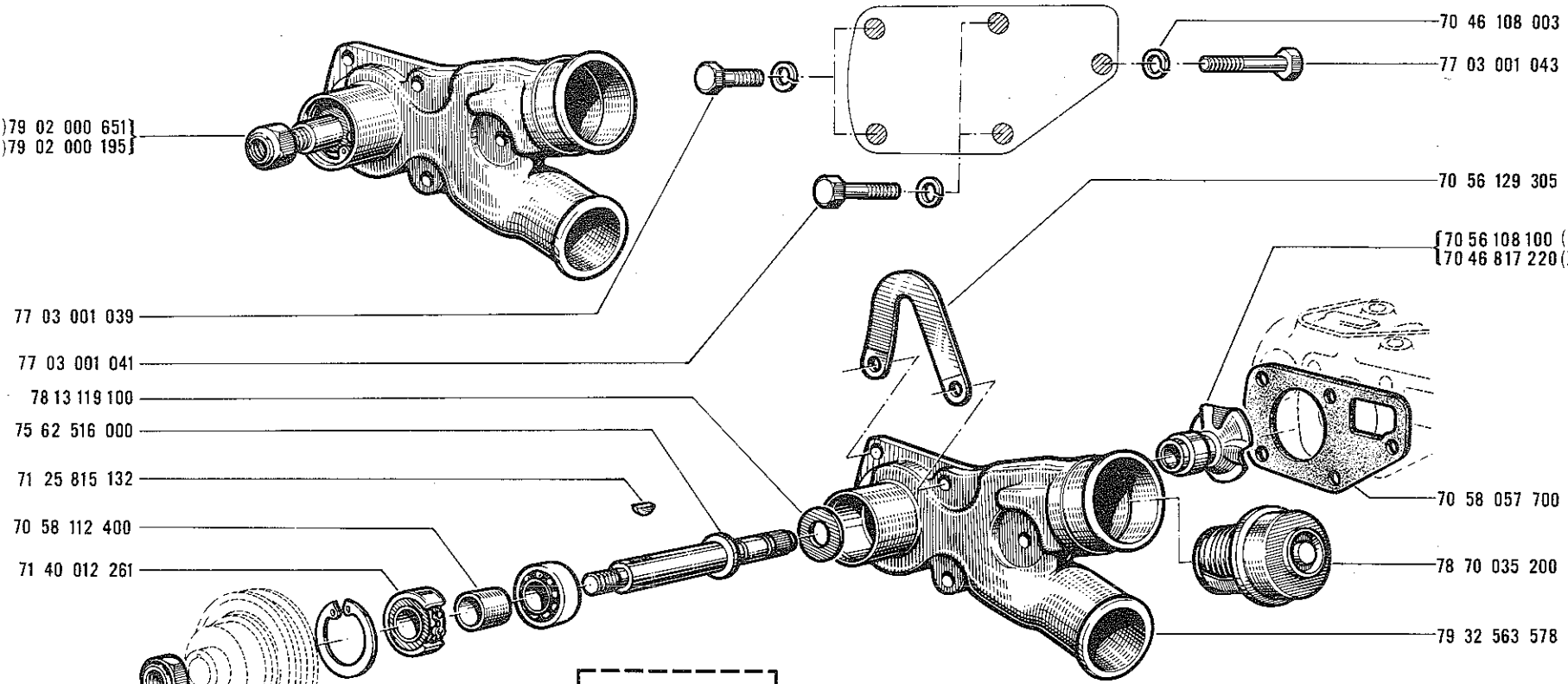

70 46 310 703

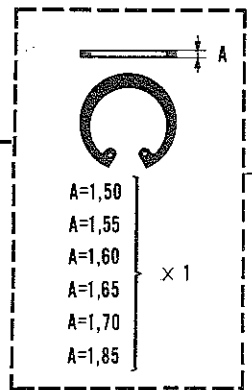

79 02 000 928

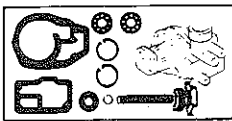

**27.05**

A P.R.915

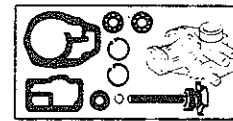

**27.05**

A P.R.915

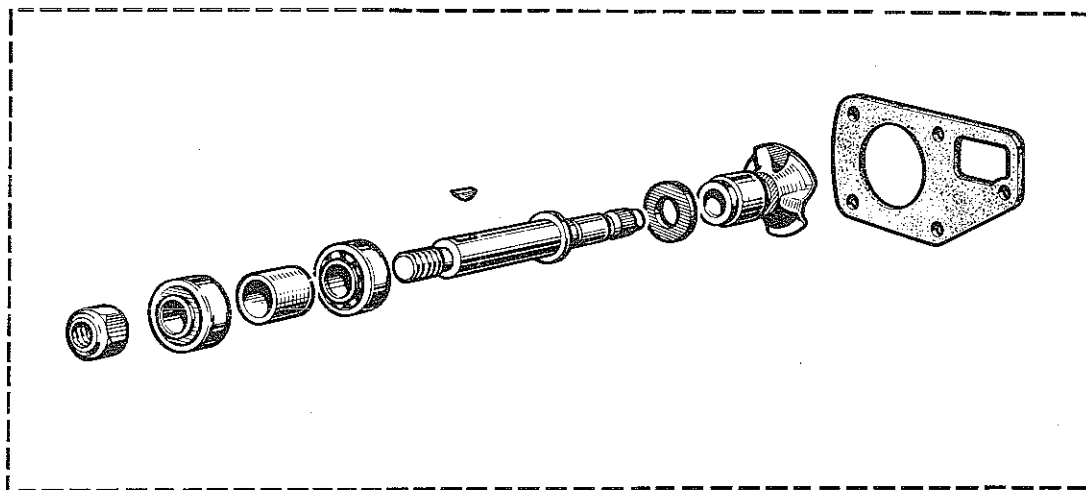
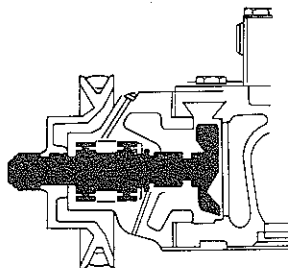

[ 75 72 711 000 (XDP 4.88)  
[ 79 02 000 929 (XDP 4.90)



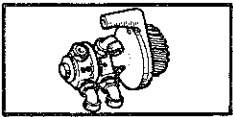

**27.10**

A P.R. 915

**27.10**

A P.R. 915

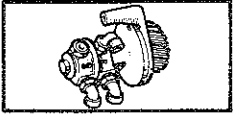

79 02 002 094

79 02 002 089

70 46 108 203

77 03 001 088

79 02 002 057

79 02 002 099

71 23 021 150

79 02 002 138

77 01 007 622

79 02 002 148

77 01 007 623

79 02 002 144

79 02 002 143

79 02 002 137

79 02 002 146

79 02 002 061

77 03 001 077

70 46 108 203

79 02 002 147

79 02 002 136

79 02 002 059

08 54 244 800

08 53 787 600

79 02 002 060

79 02 002 145

79 03 032 052

79 02 002 093

77 03 066 077

79 02 002 142

79 02 002 145

79 02 002 142

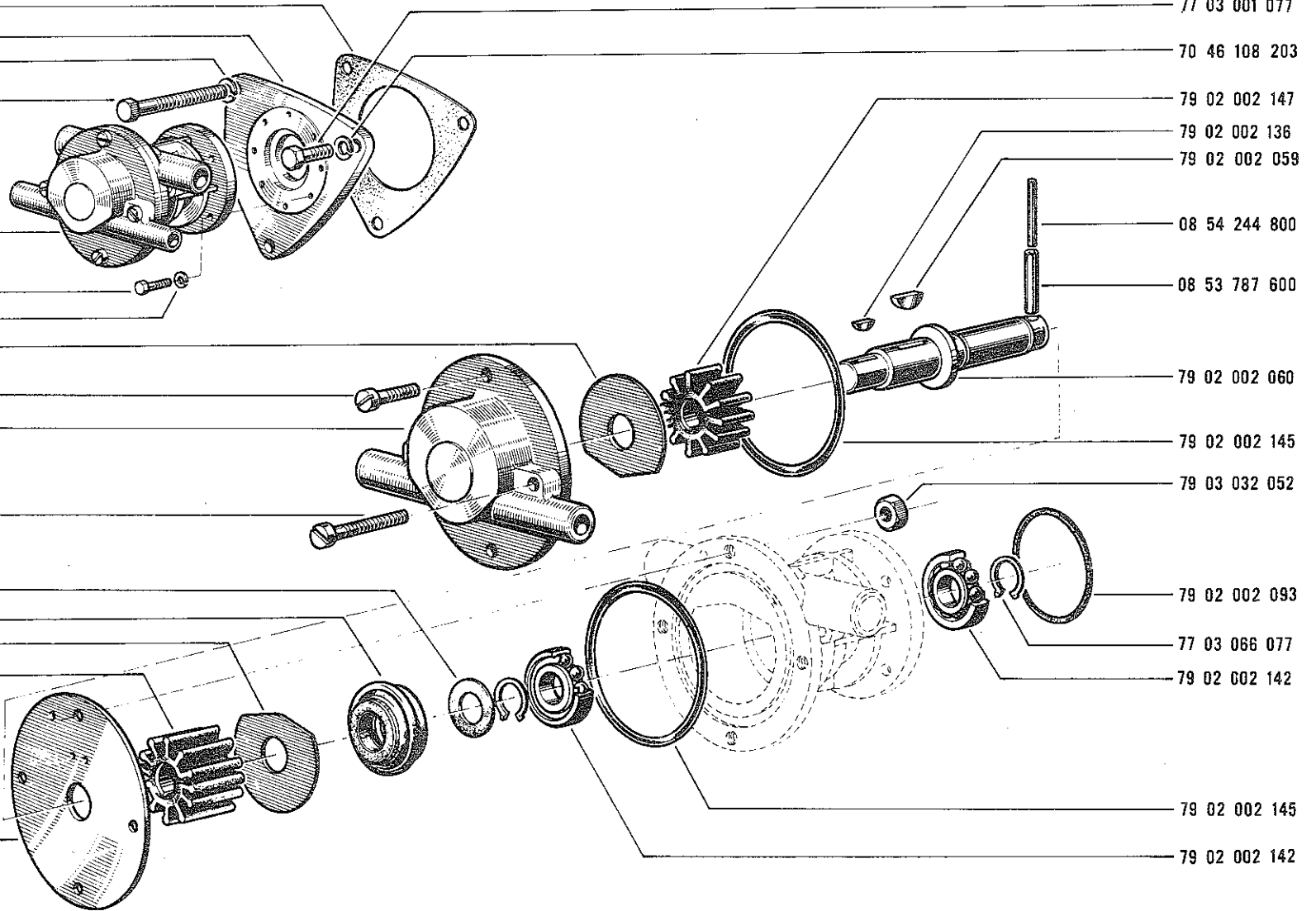

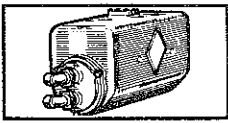

**27.15**

A P.R. 915

**27.15**

A P.R. 915

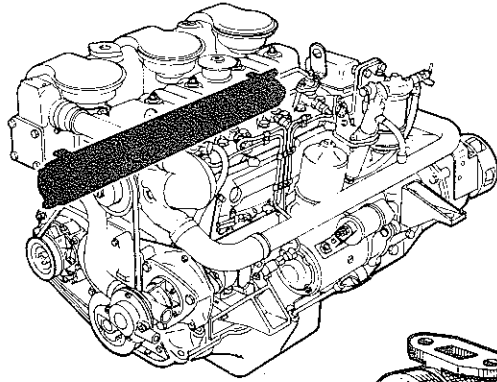
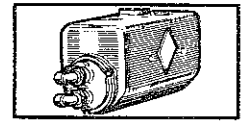

79 02 000 887

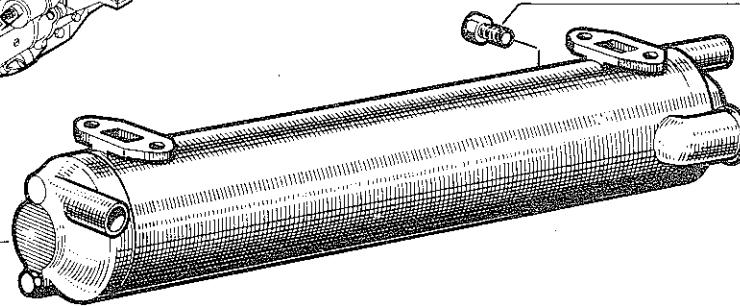

79 02 000 888

79 02 000 890

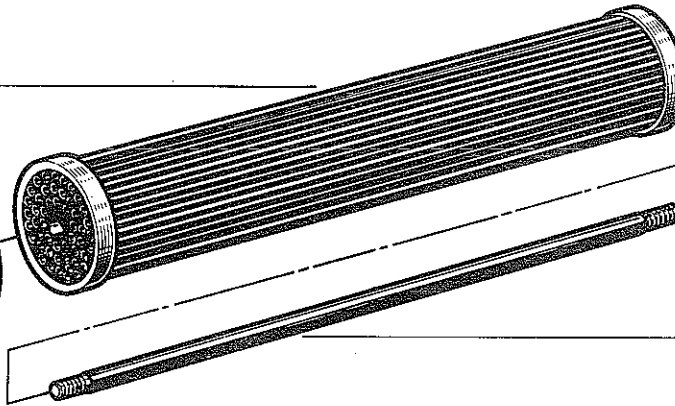

79 02 000 541

79 02 000 891

79 02 000 888

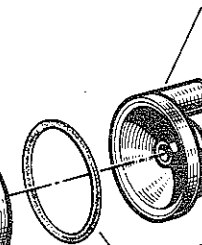

79 02 000 892

79 02 000 547

79 02 000 548

79 02 000 888

79 02 000 541

79 02 000 893

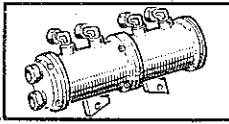

**27.25**  
A P.R.915

**4**

**27.25**  
A P.R.915

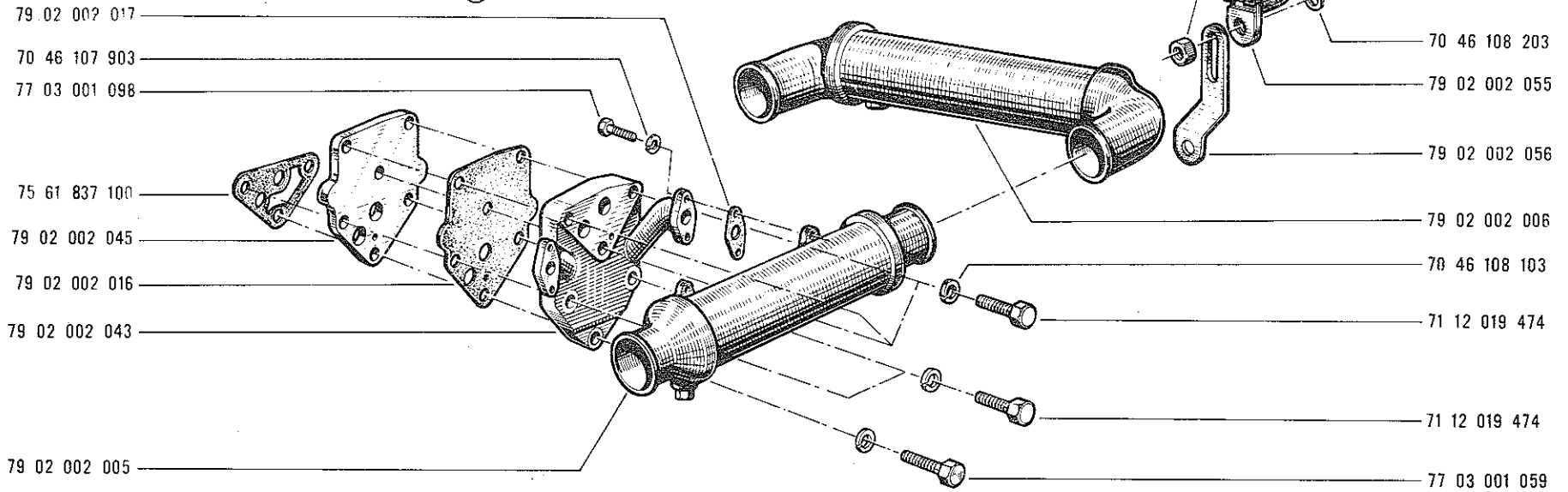
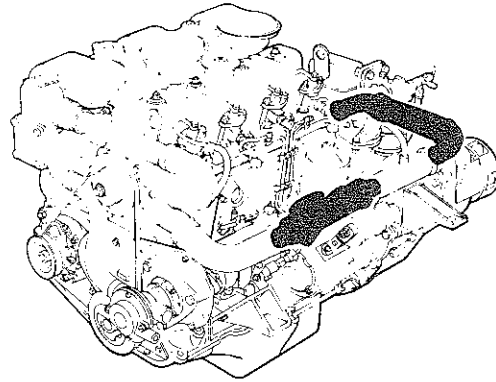
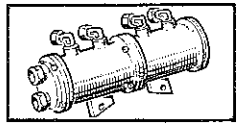

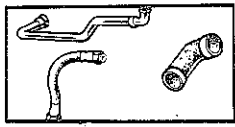

**27.30**

A P.R. 915

**3**

**27.30**

A P.R. 915

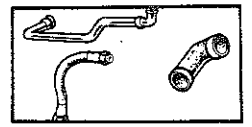

79 02 000 508

79 02 002 018

79 02 002 037

79 02 000 675

79 02 000 539

79 02 000 537

79 02 002 090

79 02 000 508

79 02 002 018

79 02 002 087

77 03 001 075

79 02 002 038

79 02 002 056

70 46 108 205

79 03 032 024

79 02 000 508

79 02 002 019

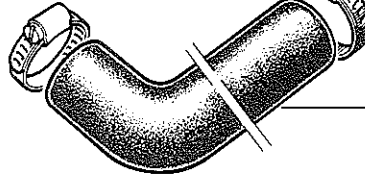
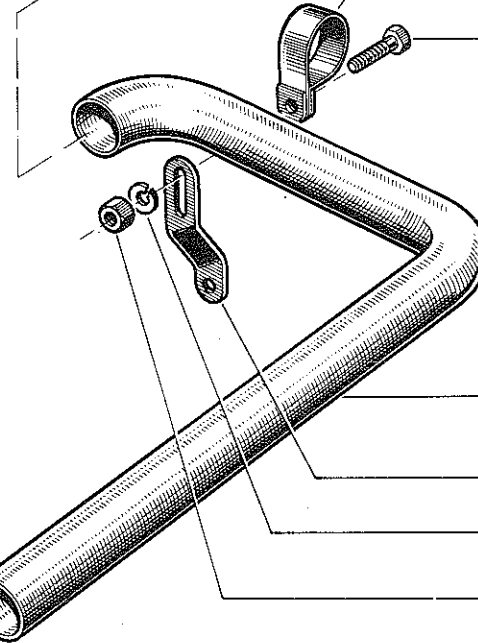
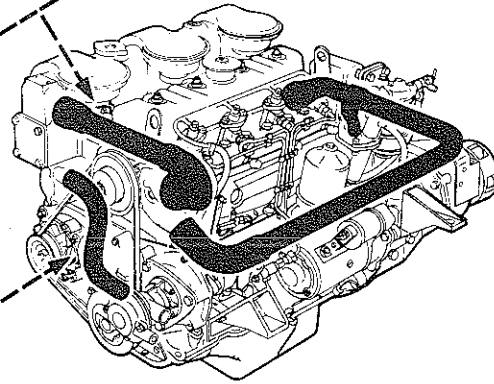
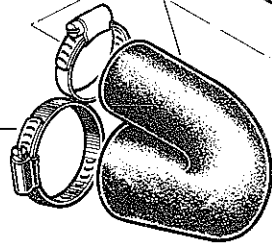
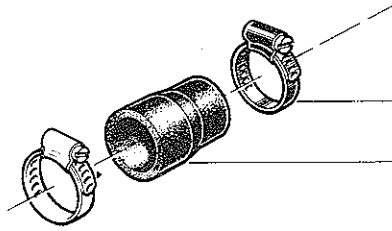
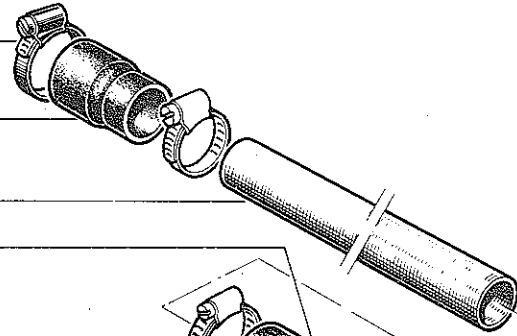

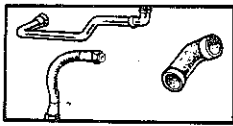

**27.35**

A P.R. 915

**4**

**27.35**

A P.R. 915

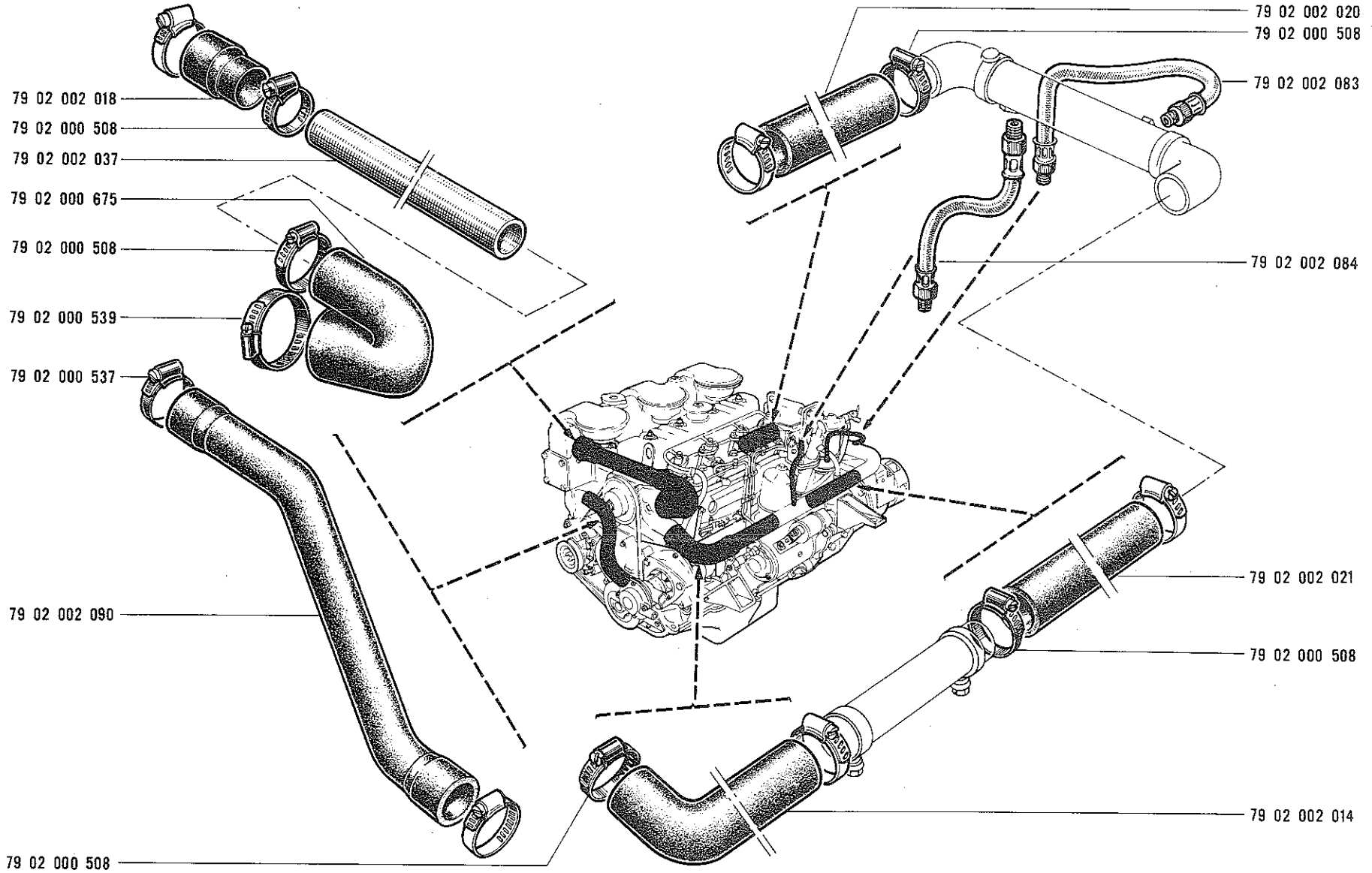
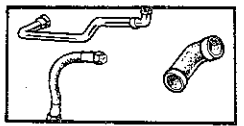



**27.50**  
A P.R.915



**27.50**  
A P.R.915

70 58 112 500

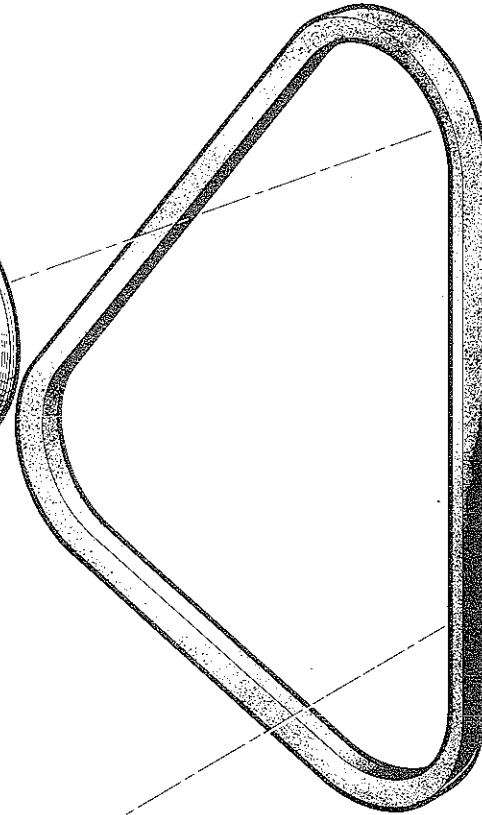
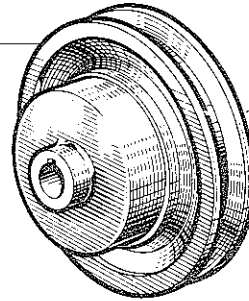
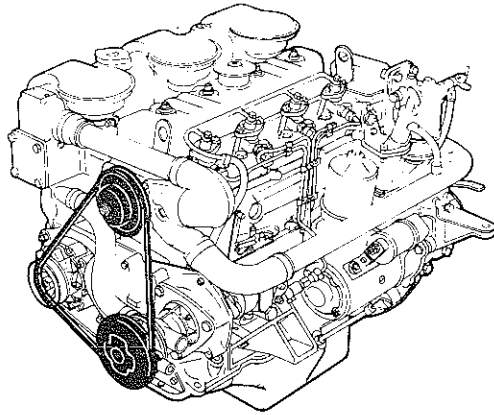

79 02 000 604

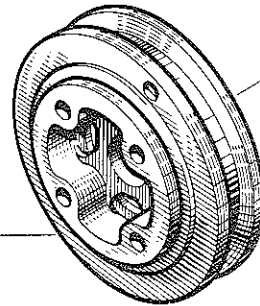

{XDP 4.88}70 58 126 200}  
{XDP 4.90}75 62 088 200}

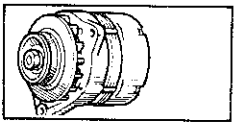

**28.20**

A P.R.915

**28.20**

A P.R.915

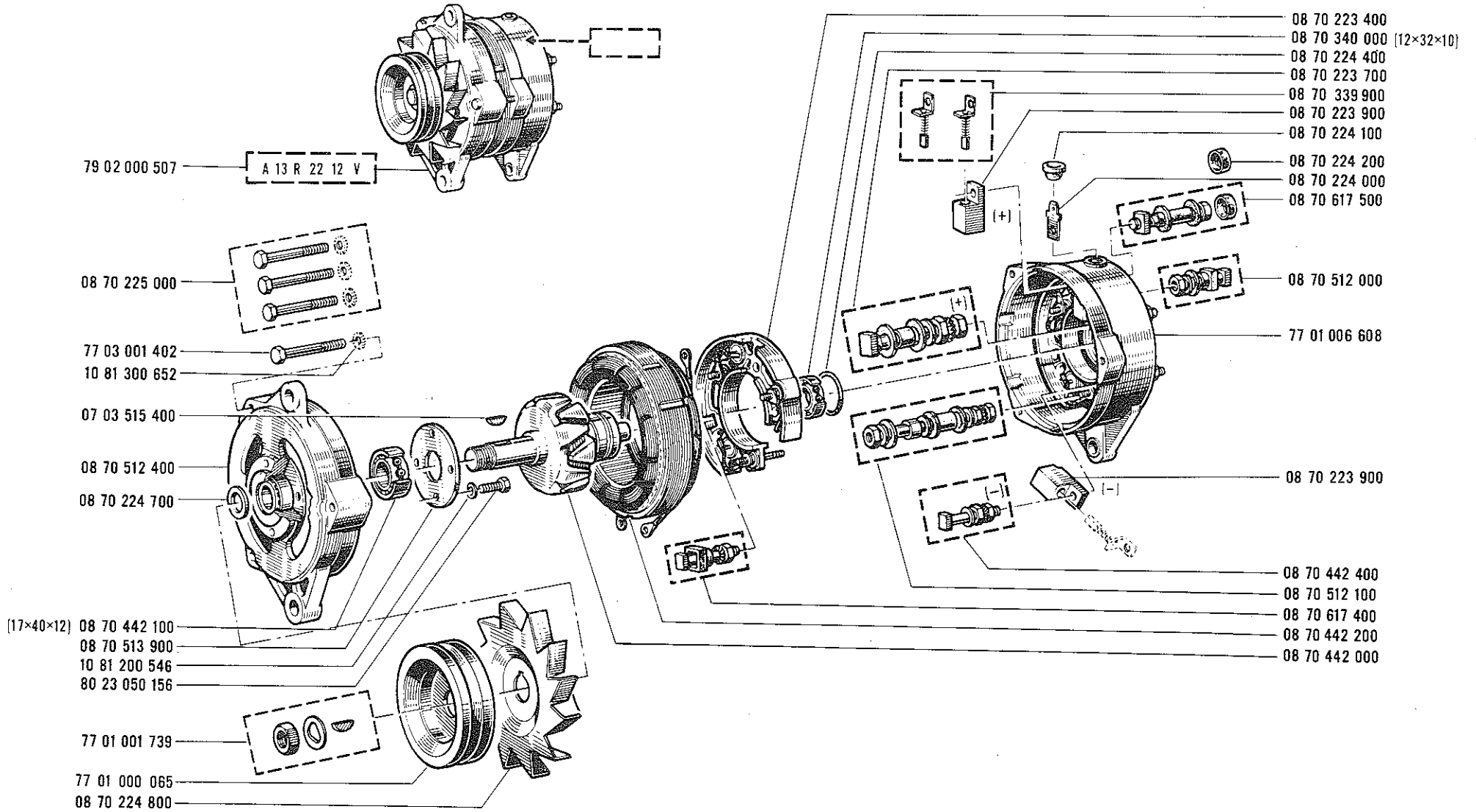
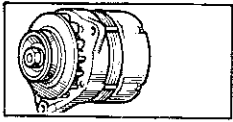

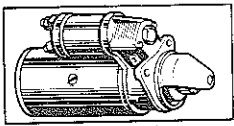

**28.30**

A P.R.915

XDP 4.88

**28.30**

A P.R.915

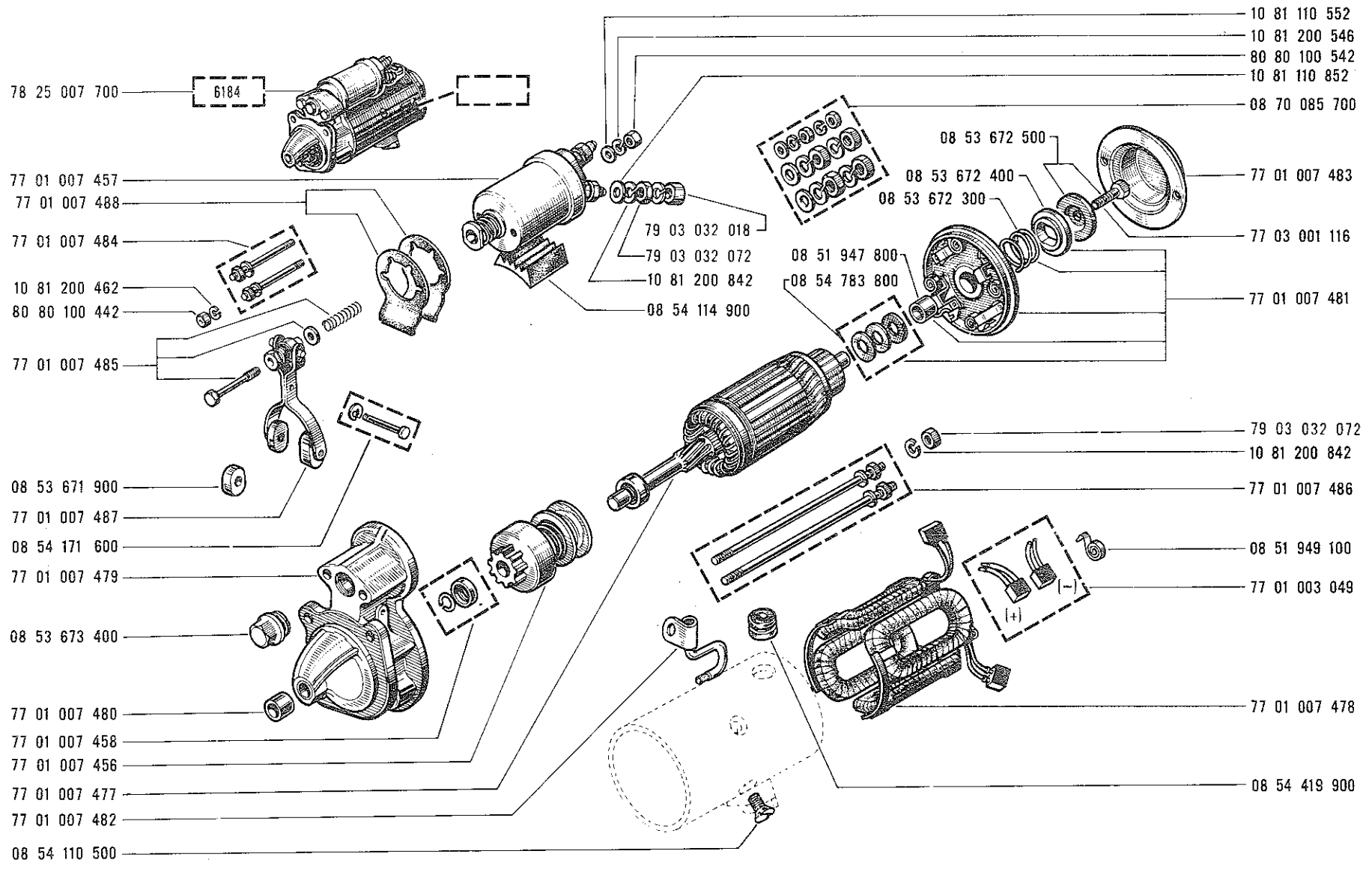
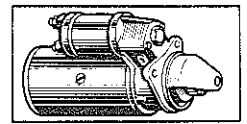



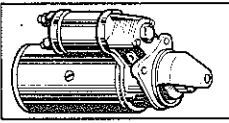

**28.35**  
A P.R. 915

XDP 4.90

**28.35**  
A P.R. 915

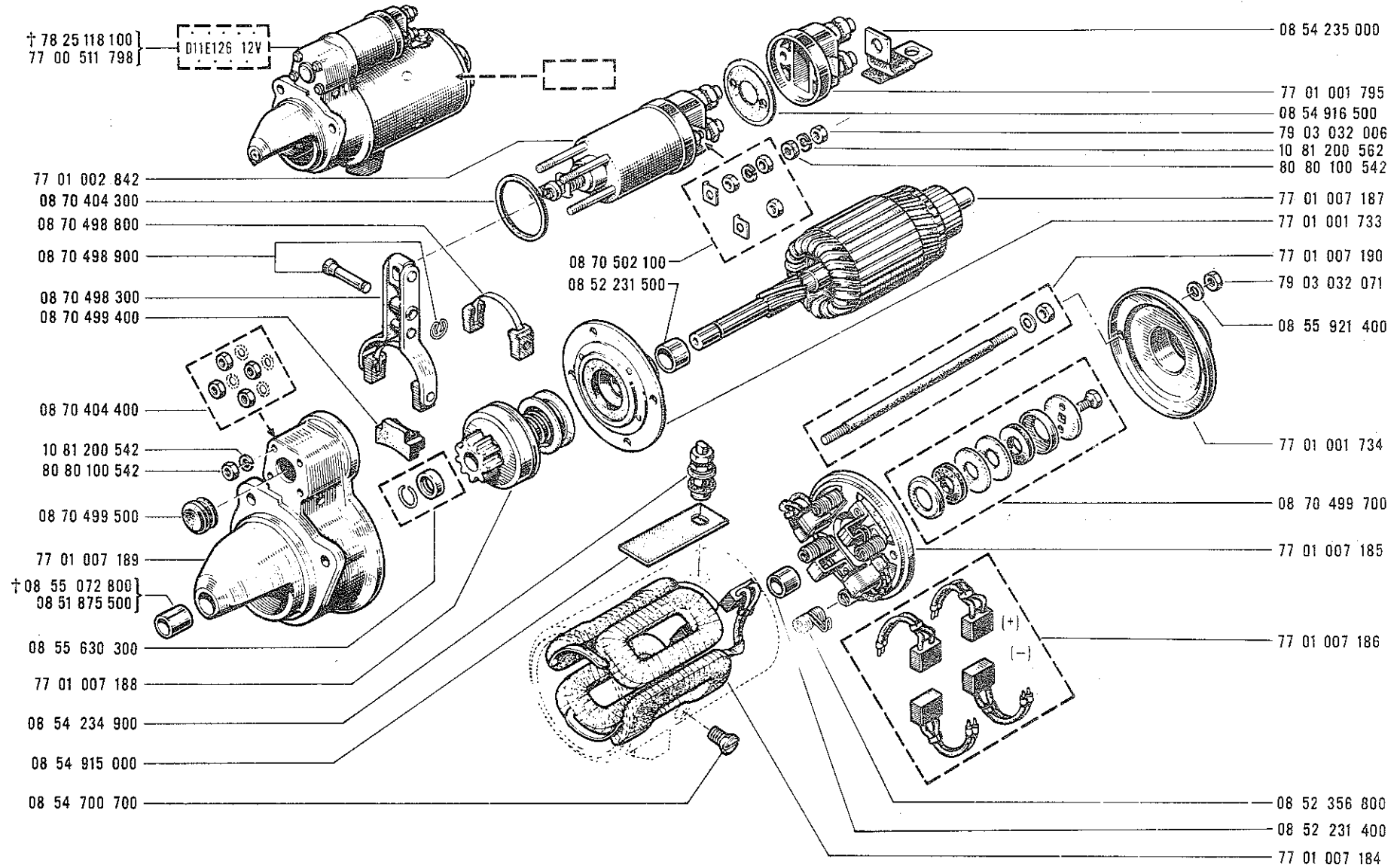
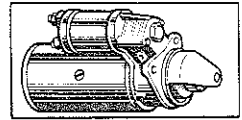

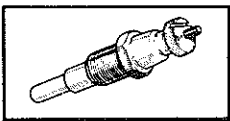

**28.65**

A P.R.915

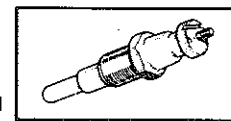

**28.65**

A P.R.915

75 61 274 100

70 58 107 200

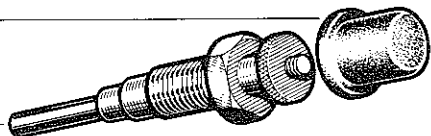

70 46 759 410

70 46 294 710

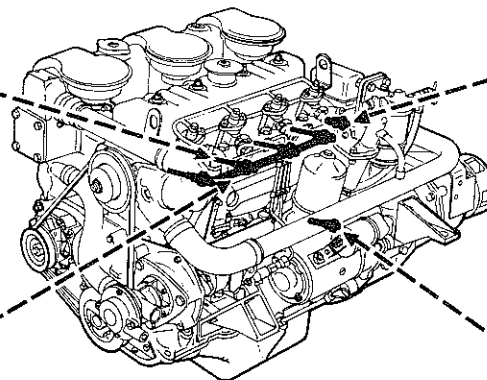
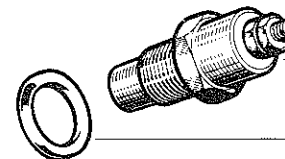

70 58 107 300

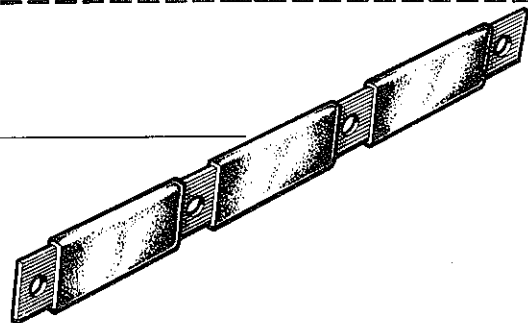

79 03 032 004

71 23 032 137

78 05 055 200

70 46 000 300

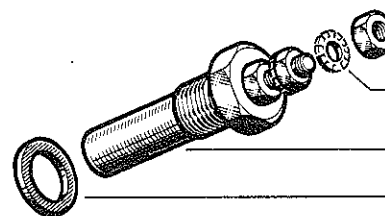

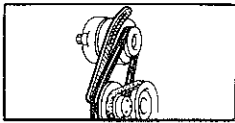

**28.80**

A P.R. 915

**28.80**

A P.R. 915

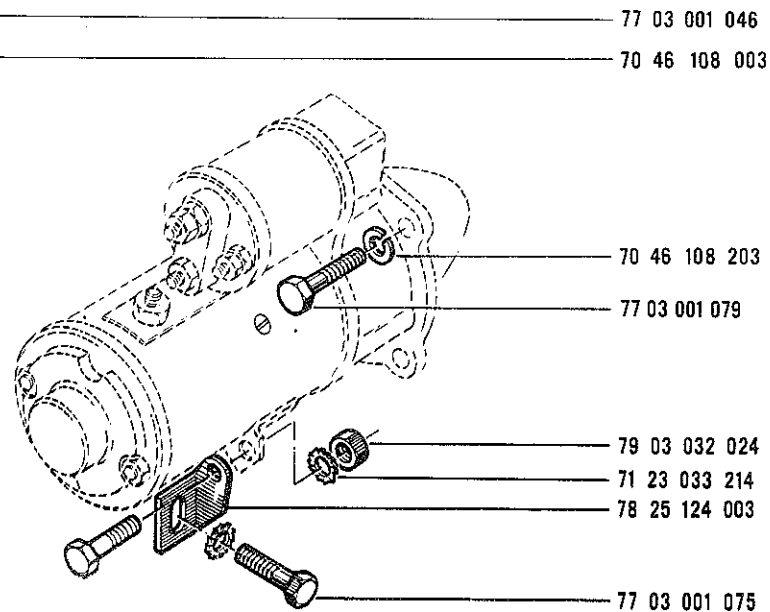
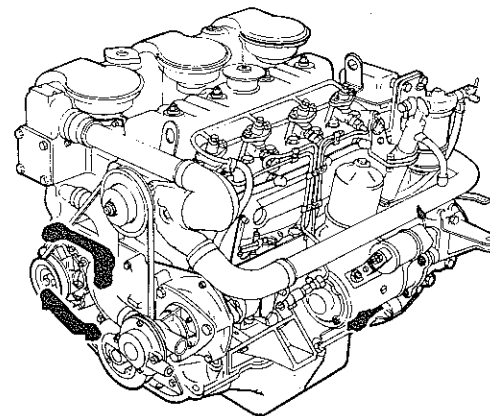
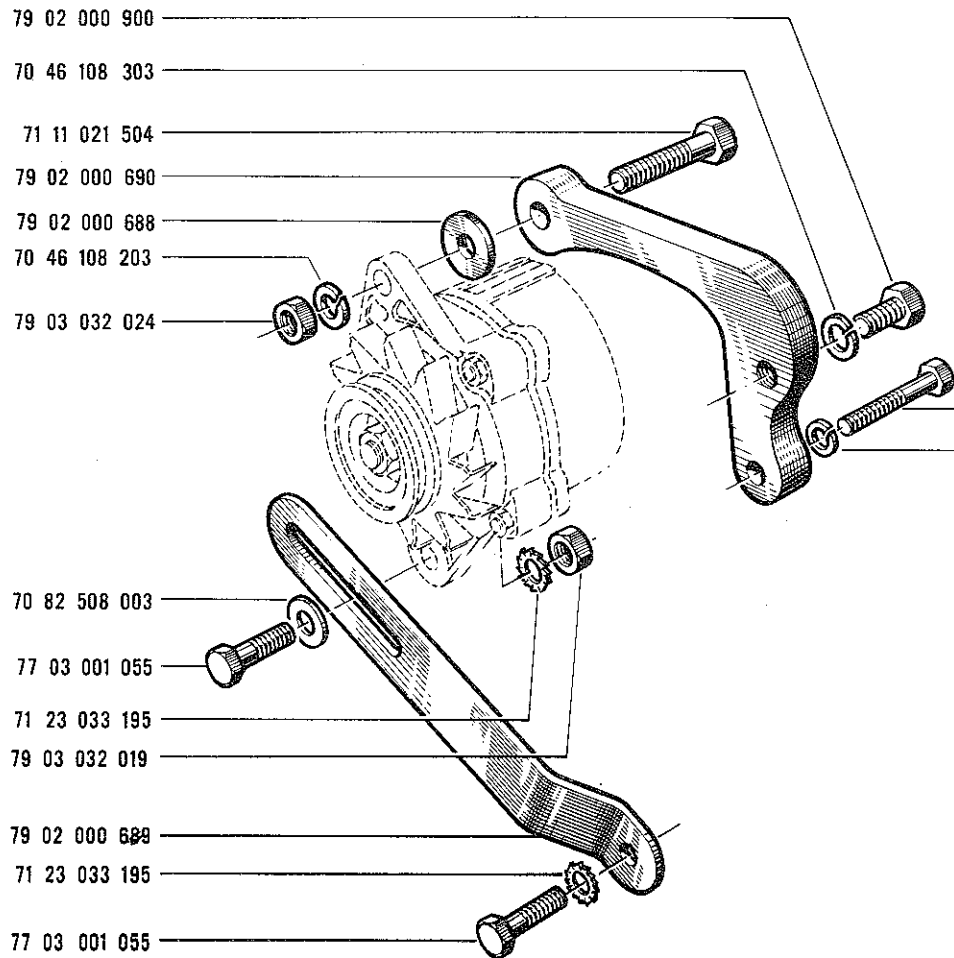
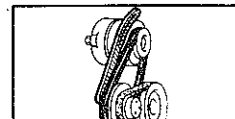

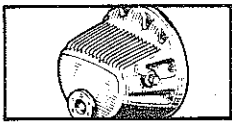

**33.01**  
A P.R.915

**3**

**33.01**  
A P.R.915

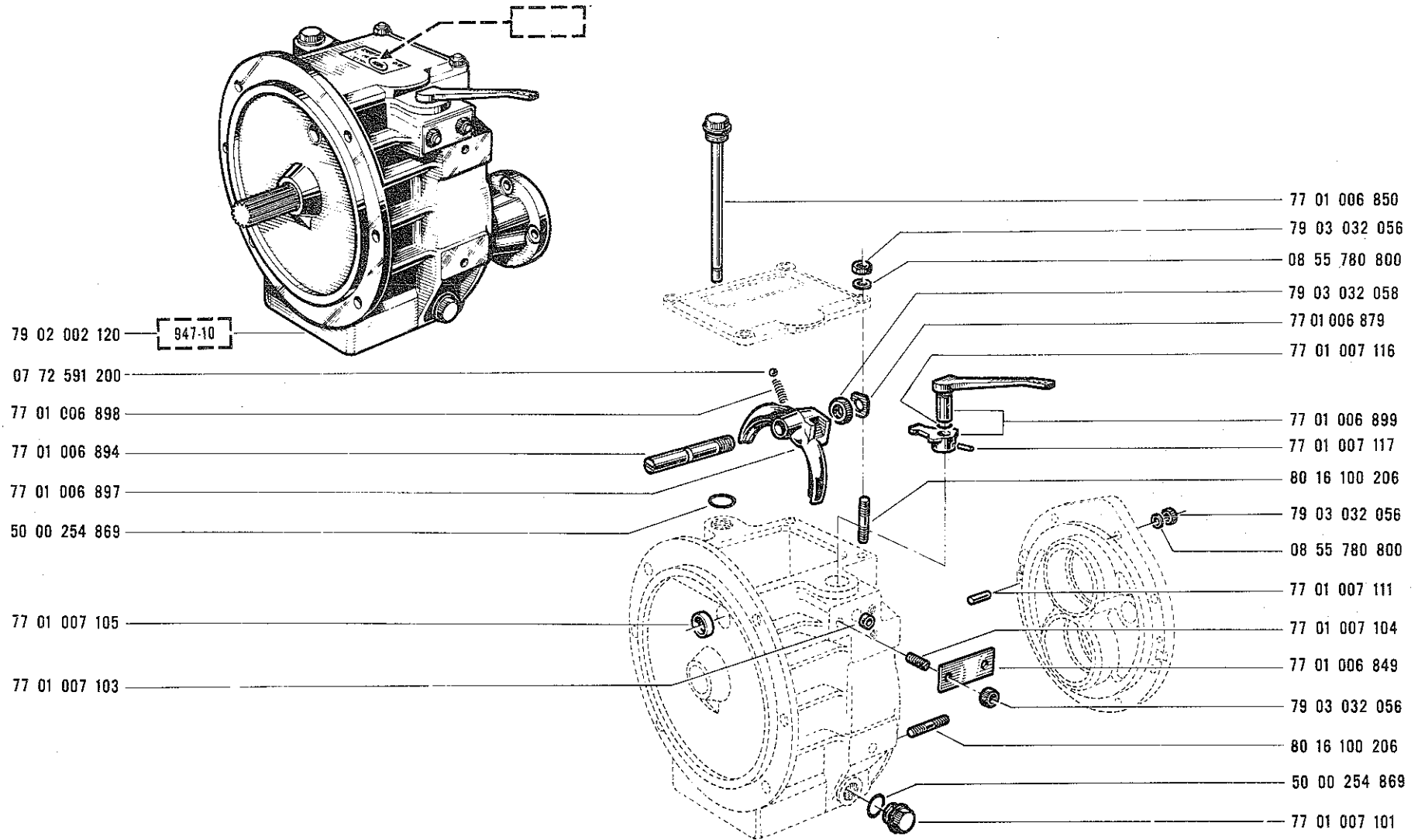
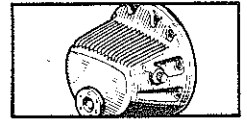

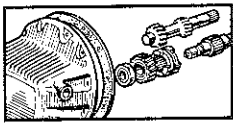

**33.03**  
A P.R. 915



**33.03**  
A P.R. 915

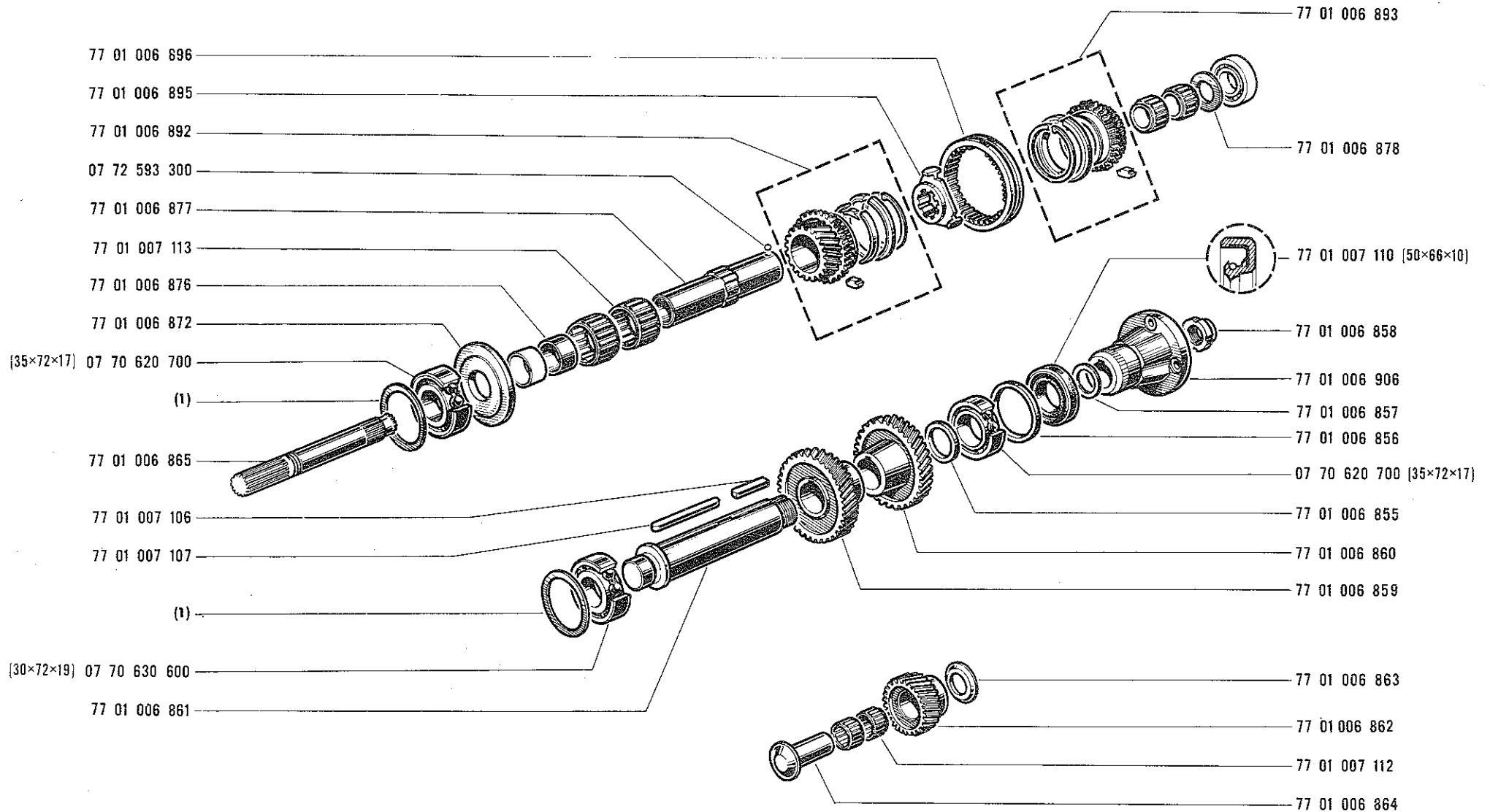
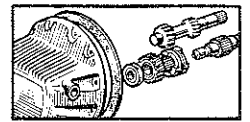

(1)		A
77 01 006 851	A=0,10	
77 01 006 852	A=0,15	
77 01 006 853	A=0,20	
77 01 006 854	A=0,25	

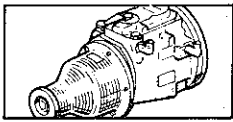

**33.10**

A P.R.915

**4**

**33.10**

A P.R.915

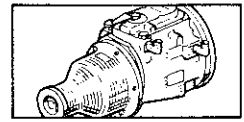

79 02 000 616

AS 1 70 CR

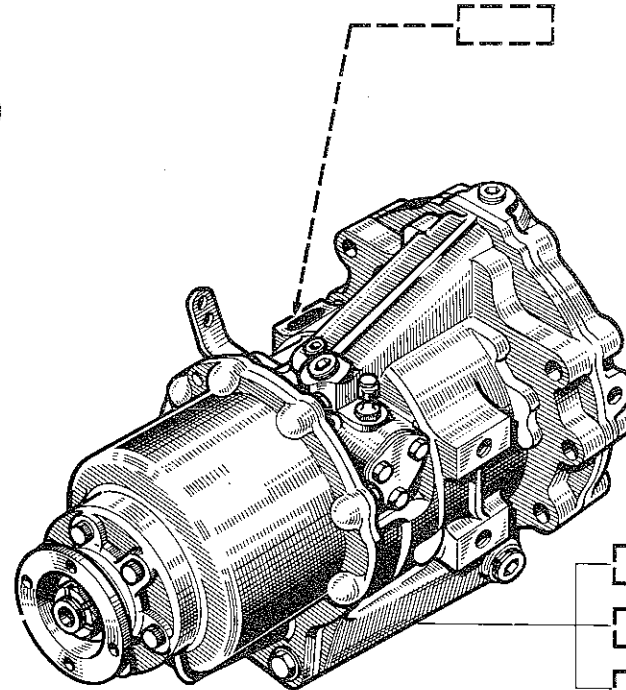
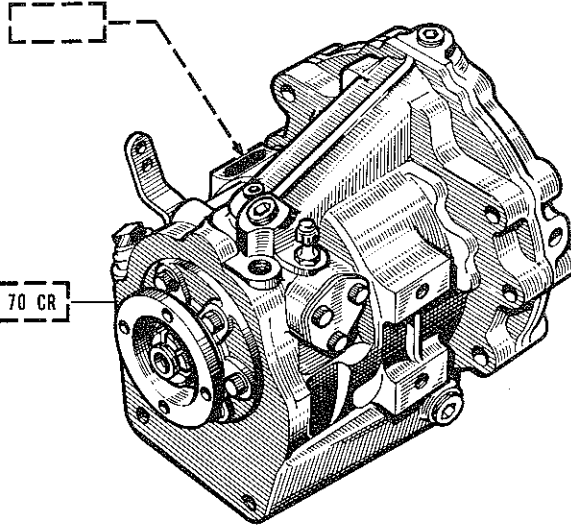

AS 5 70 CR

79 02 000 930

AS 3 70 CR

79 02 000 931

AS 7 70 CR

79 02 000 932

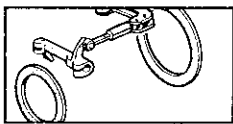

**33.12**

A P.R.915



**33.12**

A P.R.915

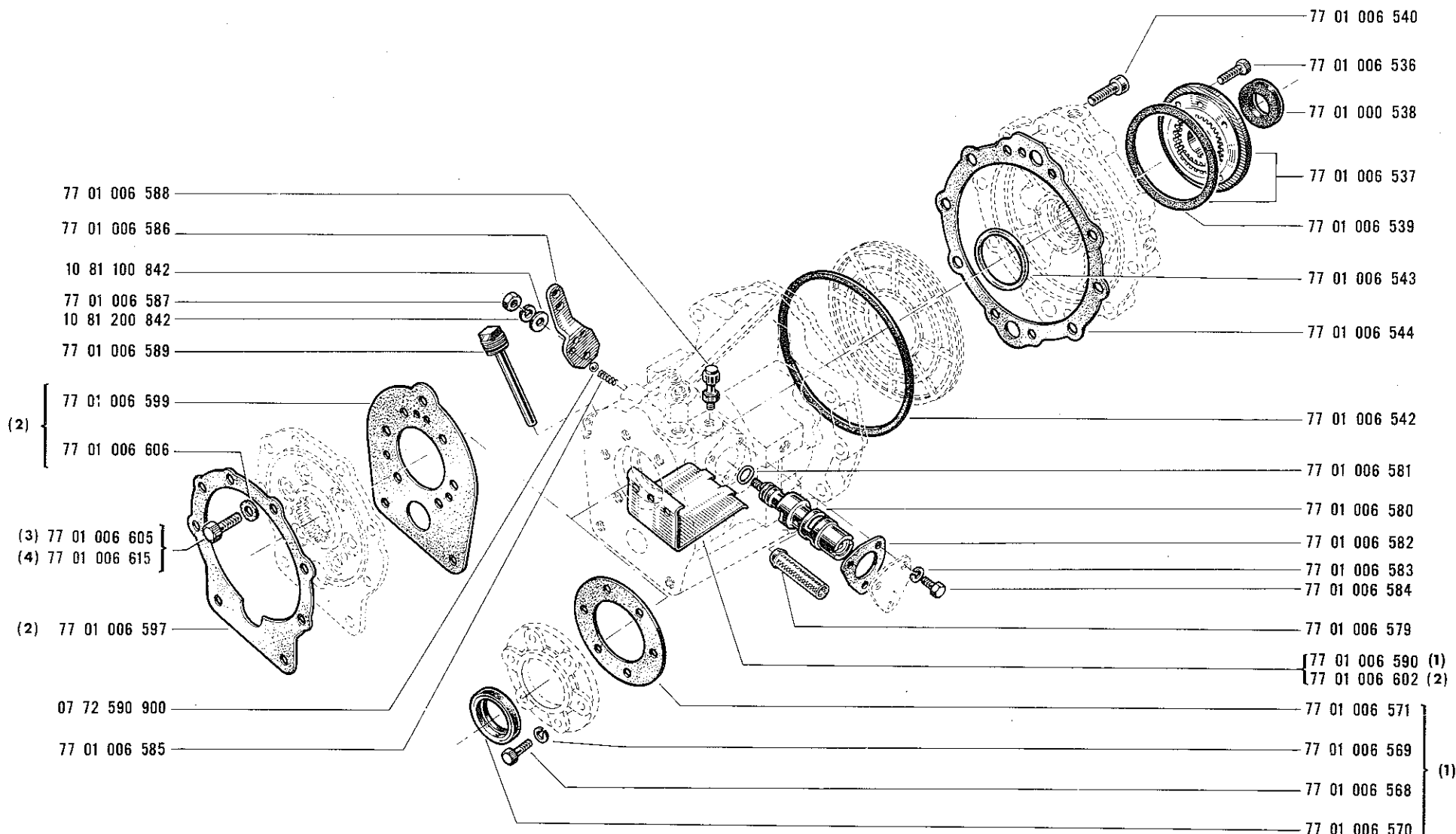
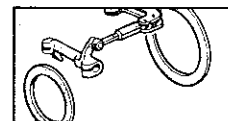

- (1)  MEC AS1.70 CR
- (2)  MEC AS1.70 CR
- (3)  MEC AS3.70 CR
- (4)  MEC AS5.70 CR

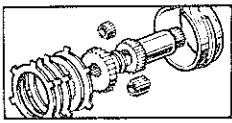

**33.14**

A P.R. 915

**4**

**33.14**

A P.R. 915

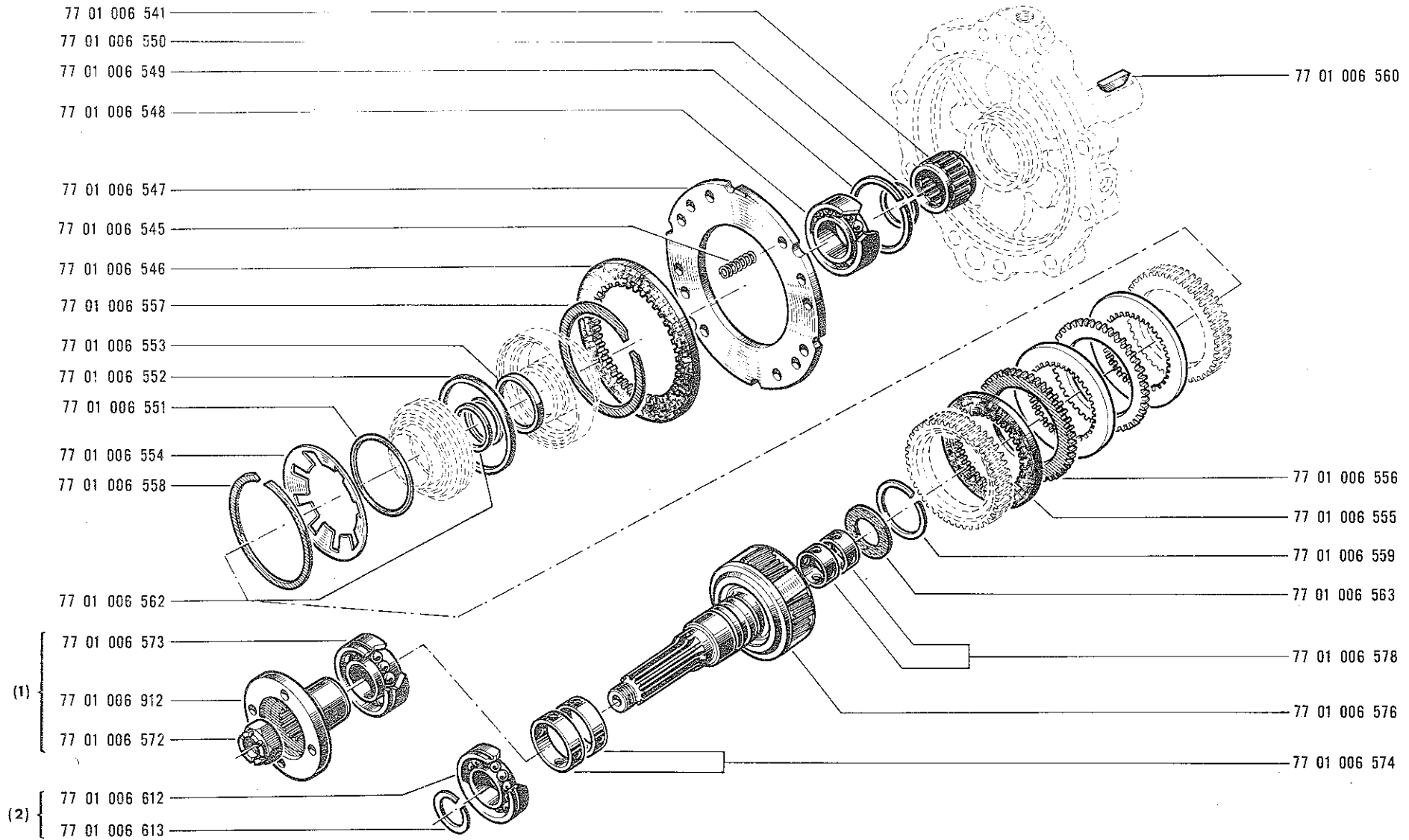
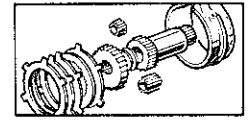

- |     |                        |
|-----|------------------------|
| (1) | MEC AS1.70CR           |
| (2) | MEC AS5.70CR, AS7.70CR |



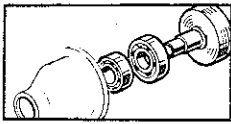

**33.16**  
A P.R. 915

**4**

**33.16**  
A P.R. 915

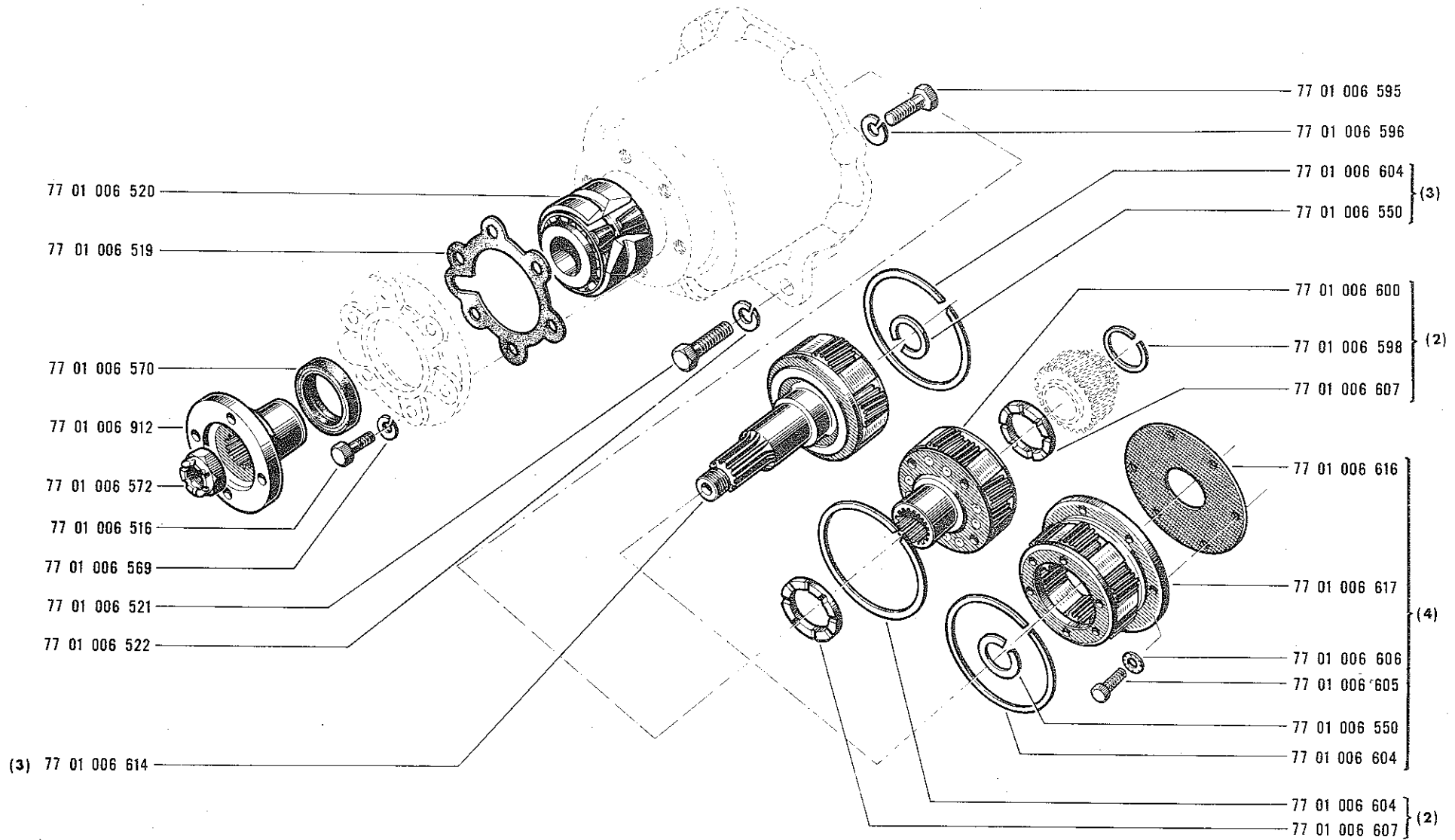
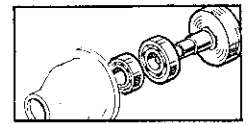

- (2) AS3.70 CR
- (3) AS5.70 CR
- (4) AS7.70 CR

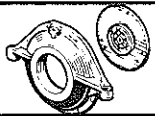

**33.50**

A P.R. 915

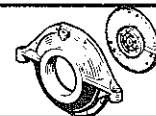

**33.50**

A P.R. 915

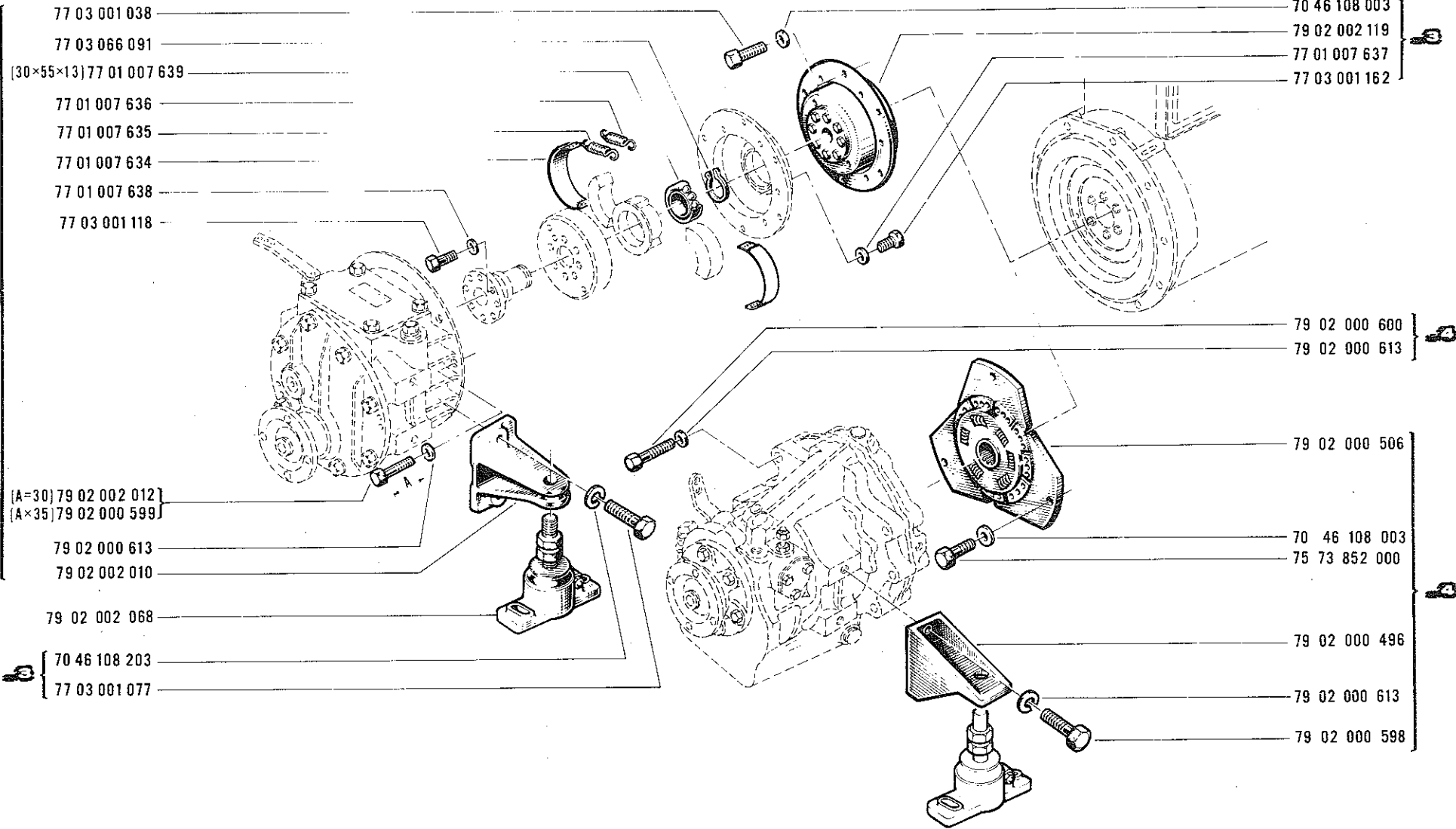

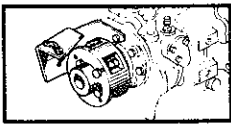

**33.70**

A P.R. 915

**33.70**

A P.R. 915

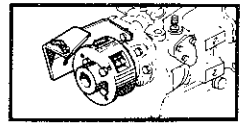

79 02 002 073

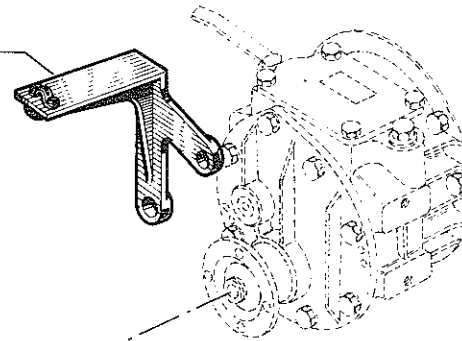

77 01 007 633

77 01 007 630

77 01 007 629

77 01 007 632

79 02 002 078

77 01 007 628

77 01 007 631

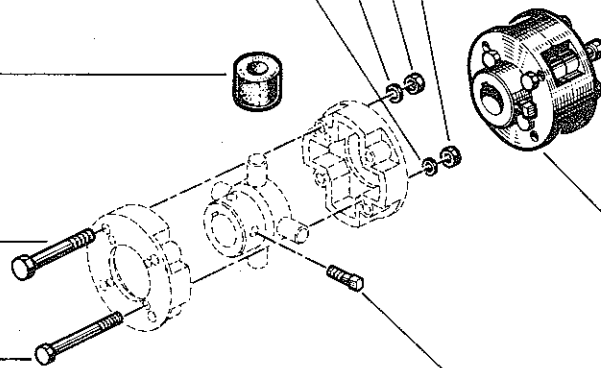

79 02 002 030

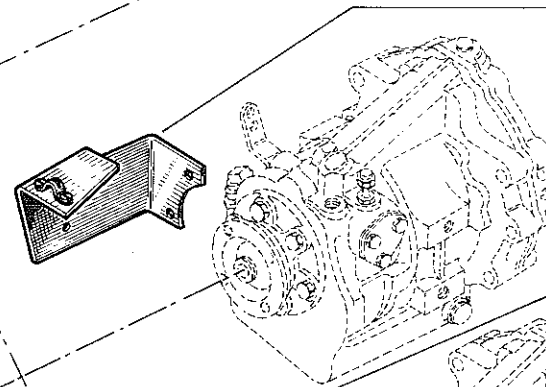

79 02 002 029

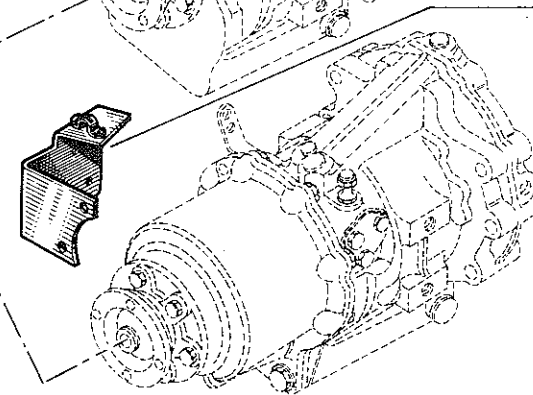

79 02 002 075

77 01 007 627

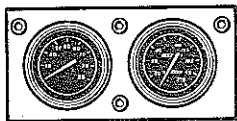

61 .01

A P.R. 915

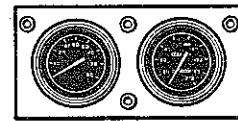

61 .01

A P.R. 915

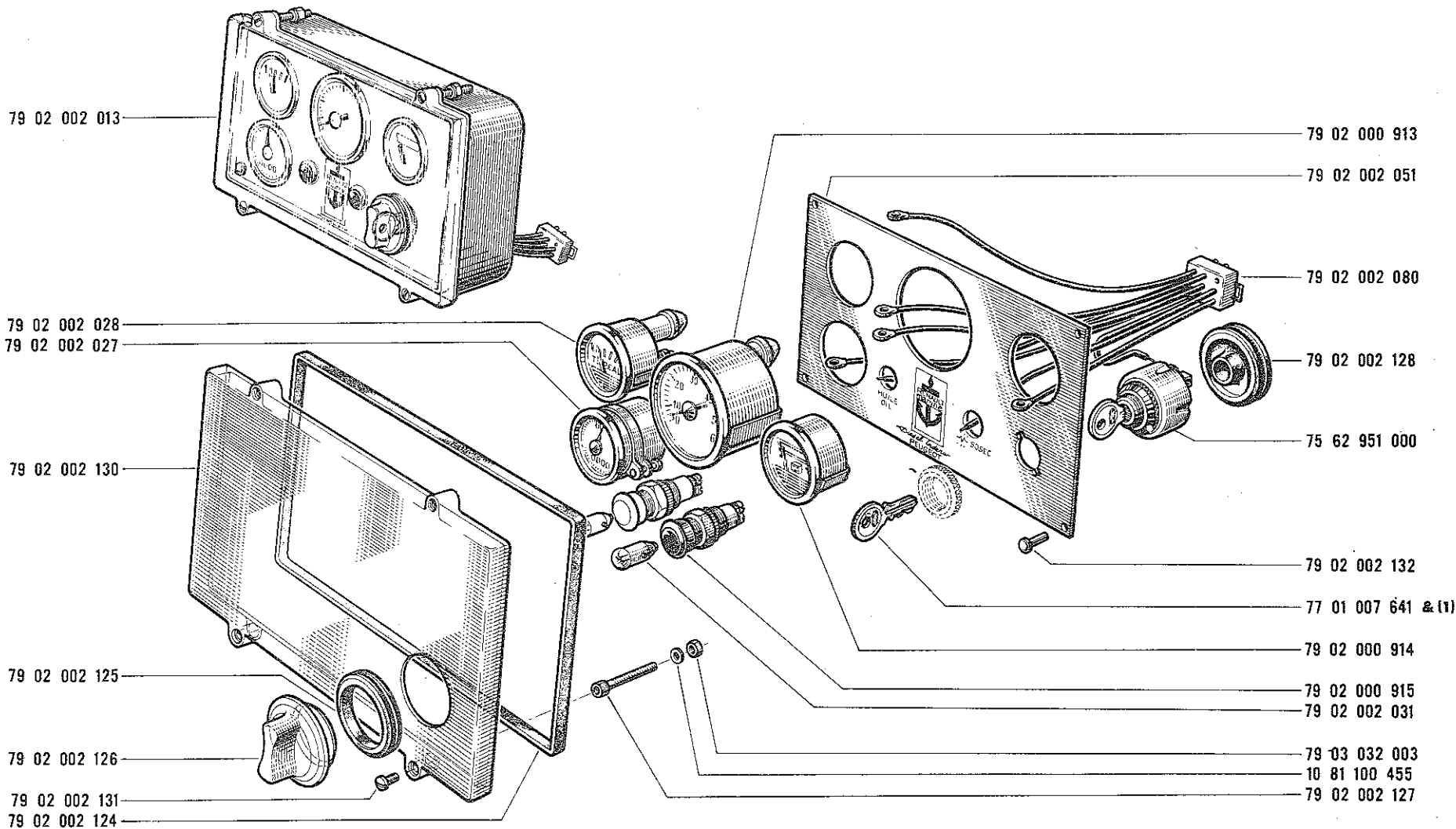

(1)

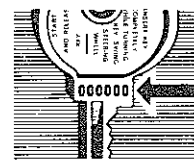

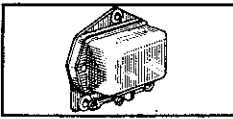

**61 .10**

A P.R. 915

**61 .10**

A P.R. 915

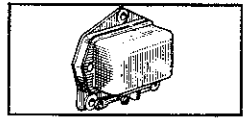

*18.00*  
*20.00*

79 02 002 044

79 02 000 599

79 02 000 613

79 02 000 608

*870730 / 1164*

79 02 002 065

70 46 108 003

79 03 032 013

79 02 000 584

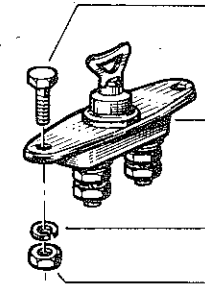
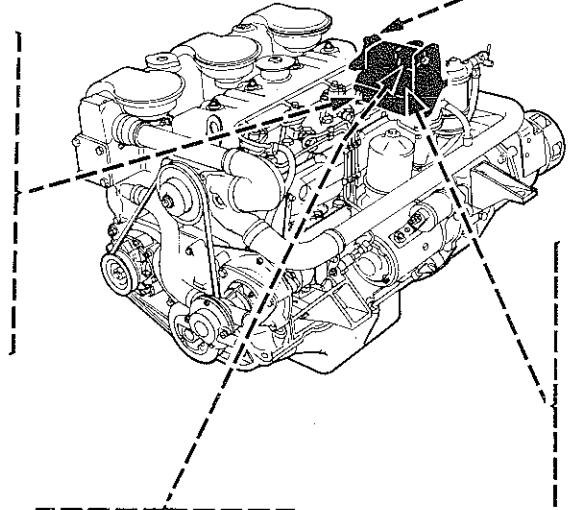

77 03 001 038

79 02 000 517

70 46 108 003

71 18 512 184

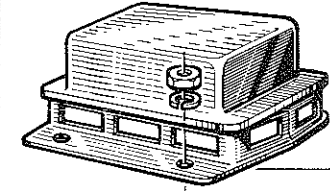

79 02 000 509

79 02 000 676

70 46 107 903

79 03 032 010

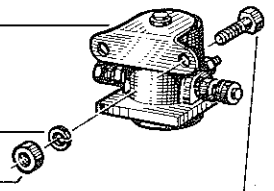

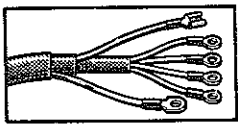

**62.50**

A P.R. 915

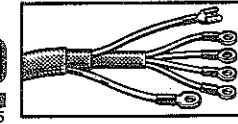

**62.50**

A P.R. 915

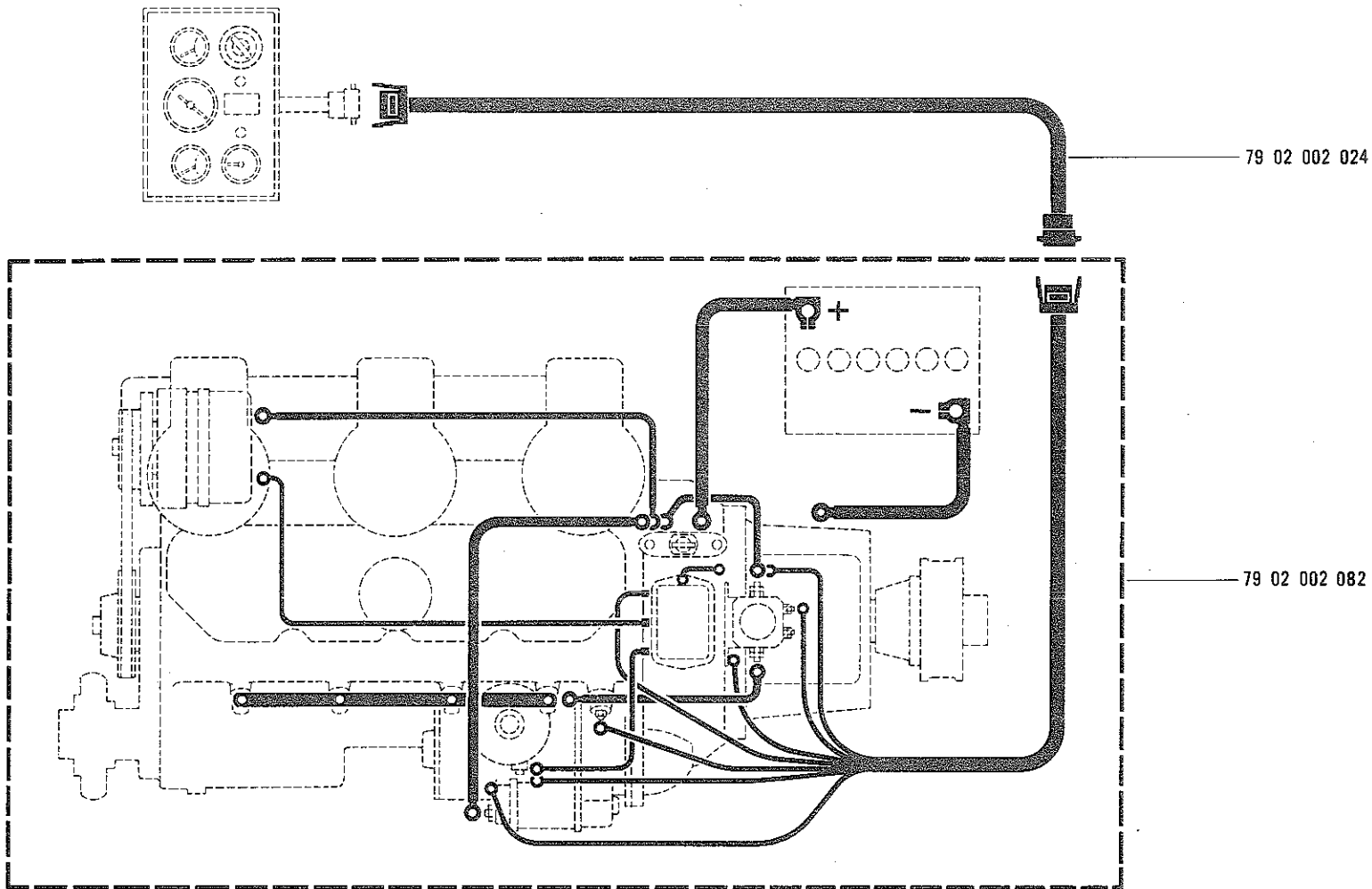

1 Ersatzteilnummer - Part Number - Numeros de las piezas - Numéro des pièces - Numero del pezzo

2 Bildtafelnummer - Plate Number - Numeros de las laminas - Numéro des planches - Numero della tavola

3 Menge pro Antriebsgruppe - Quantity per powerunit - Cantidad por grupo - Quantité par groupe - Quantita per gruppo

				1			2			3			1			2			3													
06	04	852	400	2520	08	08	54	708	800	2211	01	08	08	54	717	200	2212	02	08	08	54	748	200	2212	01	08	08	54	750	900	2203	01
07	03	304	100	2525	01	08	54	708	900	2202	01	08	08	54	717	500	2202	01	08	08	54	748	300	2203	01	08	08	54	750	900	2212	01
07	03	515	400	2820	01	08	54	708	900	2211	01	08	08	54	717	500	2211	01	08	08	54	748	300	2212	01	08	08	54	751	100	2203	02
07	03	515	700	2401	01	08	54	709	100	2202	01	08	08	54	717	600	2202	01	08	08	54	748	400	2203	01	08	08	54	751	100	2212	02
07	03	515	700	2520	01	08	54	709	100	2211	01	08	08	54	717	600	2211	01	08	08	54	748	400	2212	01	08	08	54	751	200	2203	01
07	70	620	700	3303	01	08	54	709	200	2202	01	08	08	54	717	700	2202	01	08	08	54	748	500	2203	01	08	08	54	751	300	2203	01
07	70	620	700	3303	02	08	54	709	200	2211	01	08	08	54	717	700	2211	01	08	08	54	748	500	2212	01	08	08	54	751	300	2212	01
07	70	630	600	3303	01	08	54	709	400	2202	01	08	08	54	717	800	2202	01	08	08	54	748	600	2203	02	08	08	54	783	800	2830	01
07	72	590	900	3312	01	08	54	709	500	2202	01	08	08	54	717	800	2211	01	08	08	54	748	600	2212	02	08	08	54	915	000	2835	01
07	72	591	200	3301	01	08	54	709	500	2211	01	08	08	54	718	200	2202	02	08	08	54	748	800	2203	01	08	08	54	916	500	2835	01
07	72	593	300	3303	01	08	54	710	800	2201	02	08	08	54	718	200	2211	02	08	08	54	748	800	2212	01	08	08	55	072	800	2835	01
08	51	587	300	2520	01	08	54	710	800	2210	02	08	08	54	719	000	2202	02	08	08	54	748	900	2203	01	08	08	55	079	800	2230	01
08	51	875	500	2835	01	08	54	710	900	2201	01	08	08	54	719	000	2211	02	08	08	54	748	900	2212	01	08	08	55	082	700	2230	01
08	51	947	800	2830	01	08	54	711	500	2201	01	08	08	54	719	100	2202	01	08	08	54	749	000	2203	02	08	08	55	082	800	2230	01
08	51	949	100	2830	02	08	54	711	500	2201	08	08	08	54	719	100	2211	01	08	08	54	749	000	2212	02	08	08	55	082	900	2230	01
08	52	231	400	2835	01	08	54	711	500	2210	01	08	08	54	745	800	2202	01	08	08	54	749	100	2203	02	08	08	55	237	300	2210	01
08	52	231	500	2835	01	08	54	711	500	2210	08	08	08	54	745	900	2211	01	08	08	54	749	100	2212	02	08	08	55	237	500	2202	01
08	52	356	800	2835	04	08	54	711	600	2201	01	08	08	54	746	000	2202	01	08	08	54	749	200	2203	02	08	08	55	237	500	2211	01
08	53	671	900	2830	02	08	54	711	600	2210	01	08	08	54	746	000	2211	01	08	08	54	749	200	2212	02	08	08	55	237	700	2201	01
08	53	672	300	2830	01	08	54	711	700	2201	02	08	08	54	746	100	2201	01	08	08	54	749	300	2203	01	08	08	55	237	700	2210	01
08	53	672	400	2830	01	08	54	711	700	2210	02	08	08	54	746	100	2210	01	08	08	54	749	300	2212	01	08	08	55	237	900	2201	01
08	53	672	500	2830	01	08	54	711	800	2201	01	08	08	54	746	900	2201	01	08	08	54	749	400	2203	01	08	08	55	237	900	2210	01
08	53	673	400	2830	01	08	54	711	800	2210	01	08	08	54	746	900	2210	01	08	08	54	749	400	2212	01	08	08	55	238	000	2201	01
08	53	787	600	2710	01	08	54	712	200	2201	02	08	08	54	747	000	2201	01	08	08	54	749	500	2203	01	08	08	55	238	000	2210	01
08	54	110	500	2830	04	08	54	712	200	2210	02	08	08	54	747	000	2210	01	08	08	54	749	500	2212	01	08	08	55	238	100	2201	01
08	54	114	900	2830	01	08	54	712	600	2201	02	08	08	54	747	100	2201	01	08	08	54	749	600	2203	01	08	08	55	238	100	2210	01
08	54	171	600	2830	01	08	54	712	600	2210	02	08	08	54	747	100	2210	01	08	08	54	749	600	2212	01	08	08	55	238	100	2210	01
08	54	234	900	2835	01	08	54	713	100	2201	01	08	08	54	747	300	2201	01	08	08	54	749	600	2212	01	08	08	55	238	200	2201	01
08	54	235	000	2835	01	08	54	713	100	2210	01	08	08	54	747	300	2210	01	08	08	54	749	700	2203	01	08	08	55	238	200	2210	01
08	54	244	800	2710	01	08	54	713	200	2201	02	08	08	54	747	300	2210	01	08	08	54	749	700	2212	01	08	08	55	238	400	2201	01
08	54	244	800	2710	01	08	54	713	200	2201	02	08	08	54	747	500	2201	01	08	08	54	749	800	2203	01	08	08	55	238	400	2210	01
08	54	328	900	2510	04	08	54	713	200	2210	02	08	08	54	747	500	2210	01	08	08	54	749	800	2212	01	08	08	55	239	200	2201	02
08	54	419	900	2830	01	08	54	715	000	2202	01	08	08	54	747	600	2201	01	08	08	54	750	000	2203	01	08	08	55	239	200	2202	02
08	54	700	700	2835	04	08	54	715	000	2211	01	08	08	54	747	600	2210	01	08	08	54	750	000	2212	01	08	08	55	239	200	2210	02
08	54	708	500	2202	01	08	54	715	700	2203	01	08	08	54	747	700	2201	01	08	08	54	750	100	2203	01	08	08	55	239	200	2211	02
08	54	708	500	2211	01	08	54	715	700	2212	01	08	08	54	747	800	2201	01	08	08	54	750	100	2212	01	08	08	55	239	200	2211	02
08	54	708	600	2202	01	08	54	716	000	2203	01	08	08	54	747	800	2201	01	08	08	54	750	100	2212	01	08	08	55	239	200	2315	XX
08	54	708	600	2202	01	08	54	716	000	2203	01	08	08	54	747	800	2210	01	08	08	54	750	400	2203	02	08	08	55	239	200	2315	08
08	54	708	600	2211	01	08	54	716	000	2212	01	08	08	54	748	000	2203	01	08	08	54	750	400	2203	02	08	08	55	239	200	2315	08
08	54	708	600	2211	01	08	54	716	000	2212	01	08	08	54	748	000	2203	01	08	08	54	750	400	2212	02	08	08	55	239	300	2203	01
08	54	708	700	2202	04	08	54	717	000	2203	04	08	08	54	748	000	2212	01	08	08	54	750	500	2203	01	08	08	55	239	300	2212	01
08	54	708	700	2211	04	08	54	717	000	2212	04	08	08	54	748	100	2201	01	08	08	54	750	500	2212	01	08	08	55	239	300	2212	01
08	54	708	700	2211	04	08	54	717	000	2212	04	08	08	54	748	100	2201	01	08	08	54	750	500	2212	01	08	08	55	239	400	2212	01
08	54	708	800	2202	01	08	54	717	200	2203	02	08	08	54	748	100	2210	01	08	08	54	750	700	2203	01	08	08	55	239	400	2212	01
08	54	708	800	2202	01	08	54	717	200	2203	02	08	08	54	748	100	2210	01	08	08	54	750	700	2203	01	08	08	55	239	500	2203	01

1 Ersatzteilnummer - Part Number - Numeros de las piezas - Numéro des pièces - Numero del pezzo

2 Bildtafelnummer - Plate Number - Numeros de las laminas - Numéro des planches - Numero della tavola

3 Menge pro Antriebsgruppe - Quantity per powerunit - Cantidad por grupo - Quantité par groupe - Quantita per gruppo

		1			2			3			1			2			3		
08 55 239 500 2212	01	08 55 276 000 2315	01	08 70 339 900 2820	01	10 81 200 842 2830	02	70 46 108 103 2415	02	08 55 276 200 2315	01	08 70 340 000 2820	01	10 81 200 842 2830	05	70 46 108 103 2425	04		
08 55 240 000 2202	01	08 55 276 300 2315	02	08 70 404 300 2835	01	10 81 200 842 3312	01	70 46 108 103 2501	02	08 55 276 400 2315	01	08 70 404 400 2835	01	10 81 200 862 2201	03	70 46 108 103 2605	03		
08 55 240 200 2207	01	08 55 548 700 2201	03	08 70 422 800 2315	01	10 81 200 862 2210	01	70 46 108 103 2725	06	08 55 240 200 2211	01	08 70 422 800 2315	01	10 81 200 862 2210	03	70 46 108 203 2315	02		
08 55 240 500 2202	01	08 55 550 200 2203	01	08 70 441 500 2235	01	10 81 210 666 2415	02	70 46 108 203 2710	03	08 55 240 500 2211	01	08 70 442 000 2820	01	10 81 210 669 2415	02	70 46 108 203 2725	02		
08 55 240 600 2202	01	08 55 557 300 2201	01	08 70 442 100 2820	01	10 81 300 552 2230	06	70 46 108 203 2880	01	08 55 240 600 2202	01	08 70 442 200 2820	01	10 81 300 652 2820	03	70 46 108 203 2880	03		
08 55 240 600 2211	01	08 55 557 300 2203	01	08 70 442 400 2820	01	10 81 310 552 2201	02	70 46 108 203 3350	04	08 55 240 700 2202	XX	08 70 498 300 2835	01	10 81 310 552 2203	02	70 46 108 205 2730	01		
08 55 240 700 2202	XX	08 55 557 300 2210	01	08 70 498 800 2835	01	10 81 310 552 2210	02	70 46 108 303 2425	03	08 55 240 700 2211	XX	08 70 498 900 2835	01	10 81 310 552 2212	01	70 46 108 303 2880	01		
08 55 240 800 2202	XX	08 55 630 300 2835	01	08 70 499 400 2835	01	10 81 310 552 2212	02	70 46 109 603 2230	02	08 55 240 800 2207	XX	08 70 499 500 2835	01	50 00 254 869 3301	01	70 46 122 500 2401	01		
08 55 240 800 2207	01	08 55 670 500 2203	01	08 70 499 700 2835	01	70 05 889 513 2601	02	70 46 165 600 2601	04	08 55 240 800 2211	01	08 70 502 100 2835	01	70 40 023 010 2520	XX	70 46 165 600 2605	01		
08 55 240 800 2211	01	08 55 670 600 2203	01	08 70 512 000 2820	02	70 44 278 400 2525	08	70 46 221 900 2525	01	08 55 240 900 2202	XX	08 70 512 100 2820	01	70 44 852 800 2415	01	70 46 285 003 2510	04		
08 55 240 800 2211	01	08 55 670 900 2202	XX	08 70 512 400 2820	01	70 46 000 300 2430	02	70 46 294 710 2865	01	08 55 240 900 2207	XX	08 70 513 900 2820	01	70 46 000 300 2865	01	70 46 299 503 2501	10		
08 55 240 900 2202	XX	08 55 670 900 2211	XX	08 70 553 100 2211	01	70 46 006 600 2601	01	70 46 310 703 2701	01	08 55 240 900 2211	XX	08 70 556 300 2212	01	70 46 014 510 2401	06	70 46 312 603 2430	02		
08 55 240 900 2211	XX	08 55 780 800 3301	04	08 70 577 700 2201	03	70 46 060 800 2230	02	70 46 348 300 2415	01	08 55 241 000 2207	XX	08 70 577 700 2201	03	70 46 066 303 2501	02	70 46 361 200 2401	01		
08 55 241 000 2207	XX	08 55 780 800 3301	08	08 70 617 400 2820	01	70 46 066 303 2501	02	70 46 362 900 2520	08	08 55 241 000 2211	XX	08 70 617 500 2820	01	70 46 083 300 2525	01	70 46 622 900 2520	08		
08 55 241 000 2211	XX	08 55 921 400 2835	02	08 70 617 500 2820	01	70 46 098 910 2510	01	70 46 724 300 2510	01	08 55 241 100 2201	03	10 81 100 455 6101	04	70 46 098 910 2510	01	70 46 759 410 2865	01		
08 55 241 100 2201	03	08 70 047 200 2105	01	10 81 100 842 3312	01	70 46 107 903 2425	03	70 46 816 500 2401	01	08 55 241 100 2211	01	10 81 110 352 2203	01	70 46 107 903 2725	04	70 46 817 220 2701	01		
08 55 241 100 2202	01	08 70 054 400 2315	01	10 81 110 352 2212	01	70 46 107 903 6110	06	70 46 817 220 2701	01	08 55 242 800 2105	01	10 81 110 552 2203	01	70 46 107 903 6110	02	70 46 816 500 2401	01		
08 55 241 100 2211	01	08 70 054 500 2315	01	10 81 110 552 2212	01	70 46 108 003 2430	20	70 47 127 400 2601	01	08 55 242 800 2105	01	10 81 110 552 2212	01	70 46 108 003 2615	02	70 56 079 000 2520	01		
08 55 242 800 2105	01	08 70 085 700 2830	01	10 81 110 552 2830	01	70 46 108 003 2701	05	70 56 079 209 2415	01	08 55 242 900 2105	02	10 81 110 852 2830	02	70 46 108 003 2701	05	70 56 079 209 2415	01		
08 55 242 900 2105	02	08 70 192 600 2211	01	10 81 110 852 2830	02	70 46 108 003 2830	01	70 56 079 800 2430	01	08 55 243 000 2105	01	10 81 110 852 2830	02	70 46 108 003 2830	01	70 56 079 800 2430	01		
08 55 243 000 2105	01	08 70 193 100 2201	03	10 81 200 462 2830	02	70 46 108 003 3350	03	70 56 080 003 2601	01	08 55 243 100 2105	01	10 81 200 462 2830	02	70 46 108 003 3350	03	70 56 080 003 2601	01		
08 55 243 100 2105	01	08 70 193 100 2210	03	10 81 200 542 2835	04	70 46 108 003 3350	06	70 56 082 400 2415	02	08 55 243 200 2105	01	10 81 200 542 2835	04	70 46 108 003 3350	06	70 56 082 400 2415	02		
08 55 243 200 2105	01	08 70 223 400 2820	01	10 81 200 546 2820	04	70 46 108 003 6110	02	70 56 082 800 2401	04	08 55 243 300 2105	01	10 81 200 546 2820	04	70 46 108 003 6110	02	70 56 082 800 2401	04		
08 55 243 300 2105	01	08 70 223 700 2820	01	10 81 200 546 2830	02	70 46 108 103 2230	02	70 56 084 000 2230	01	08 55 243 600 2105	01	10 81 200 546 2830	02	70 46 108 103 2230	02	70 56 084 000 2230	01		
08 55 243 600 2105	01	08 70 223 900 2820	02	10 81 200 562 2835	01	70 46 108 103 2240	03	70 56 085 500 2415	01	08 55 243 800 2105	01	10 81 200 562 2835	01	70 46 108 103 2240	03	70 56 085 500 2415	01		
08 55 243 800 2105	01	08 70 224 000 2820	01																



1 Ersatzteilnummer - Part Number - Numeros de las piezas - Numéro des pièces - Numero del pezzo

2 Bildtafelnummer - Plate Number - Numeros de las laminas - Numéro des planches - Numero della tavola

3 Menge pro Antriebsgruppe - Quantity per powerunit - Cantidad por grupo - Quantité par groupe - Quantita per gruppo

			1			2			3			1			2			3		
70 56 098 600 2415	01		70 56 178 600 2401	01		70 58 069 900 2140	04		71 23 032 176 2601	03		75 62 764 000 2525	04							
70 56 100 800 2401	01		70 56 178 900 2420	01		70 58 073 700 2415	10		71 23 032 184 2420	03		75 62 765 000 2525	02							
70 56 108 000 2301	02		70 56 179 100 2501	XX		70 58 073 800 2415	04		71 23 032 184 2420	11		75 62 771 000 2525	04							
70 56 108 100 2701	01		70 56 179 200 2501	XX		70 58 098 900 2525	04		71 23 032 196 2140	08		75 62 844 000 2401	01							
70 56 112 600 2401	XX		70 56 179 300 2501	XX		70 58 106 400 2501	07		71 23 032 196 2240	01		75 62 853 000 2401	01							
70 56 112 700 2401	XX		70 56 179 400 2501	XX		70 58 106 600 2501	08		71 23 032 196 2520	02		75 62 896 000 2401	XX							
70 56 112 800 2401	XX		70 56 181 000 2501	05		70 58 107 200 2865	04		71 23 032 196 2525	02		75 62 897 000 2401	XX							
70 56 114 210 2501	XX		70 56 181 103 2501	02		70 58 107 300 2865	01		71 23 032 198 2240	02		75 62 951 000 6101	01							
70 56 114 220 2501	XX		70 56 181 200 2601	01		70 58 112 400 2701	01		71 23 032 218 2240	03		75 62 951 000 6110	01							
70 56 114 230 2501	XX		70 56 181 300 2601	01		70 58 112 500 2750	01		71 23 032 218 2525	04		75 62 968 000 2510	04							
70 56 115 400 2410	XX		70 56 183 500 2415	01		70 58 122 000 2420	01		71 23 033 195 2880	02		75 62 997 000 2240	01							
70 56 115 500 2410	XX		70 56 183 600 2415	01		70 58 122 700 2420	01		71 23 033 214 2880	02		75 63 020 100 2501	XX							
70 56 115 600 2410	XX		70 56 189 700 2525	08		70 58 126 200 2750	01		71 23 121 370 2401	08		75 63 020 200 2501	XX							
70 56 118 300 2415	02		70 56 190 100 2525	02		70 58 142 204 2401	04		71 23 122 300 2525	02		75 63 029 000 2525	01							
70 56 118 500 2301	02		70 56 190 200 2525	02		70 58 142 410 2501	XX		71 25 511 215 2501	04		75 63 093 000 2401	08							
70 56 119 600 2601	01		70 56 190 600 2415	04		70 58 142 420 2501	XX		71 25 515 297 2415	02		75 63 105 000 2230	01							
70 56 119 700 2601	01		70 56 196 600 2601	01		70 58 145 700 2530	05		71 25 815 132 2701	01		75 63 204 000 2601	01							
70 56 119 800 2601	01		70 56 198 000 2601	01		70 58 152 400 2401	04		71 40 012 261 2701	02		75 63 209 100 2401	04							
70 56 120 600 2601	01		70 56 207 600 2401	01		70 58 154 300 2401	04		71 52 632 312 2415	01		75 63 263 000 2210	01							
70 56 129 305 2701	01		70 56 208 700 2525	02		70 58 156 905 2510	01		71 52 632 312 2430	01		75 63 297 000 2525	02							
70 56 130 500 2301	01		70 56 211 000 2240	02		70 58 157 000 2510	01		75 61 274 100 2865	04		75 63 356 000 2105	04							
70 56 133 003 2501	01		70 56 213 600 2525	02		70 80 100 400 2425	02		75 61 331 100 2501	01		75 70 195 000 2410	03							
70 56 133 403 2415	01		70 56 214 104 2501	08		70 80 101 500 2415	02		75 61 333 100 2501	04		75 70 198 000 2410	XX							
70 56 133 403 2501	01		70 56 231 800 2415	01		70 81 207 900 2520	08		75 61 837 100 2605	01		75 70 199 000 2410	XX							
70 56 135 500 2520	01		70 56 234 800 2301	01		70 82 011 906 2301	02		75 61 837 100 2725	01		75 70 200 000 2410	XX							
70 56 135 600 2520	01		70 56 234 900 2301	01		70 82 508 003 2880	01		75 61 905 100 2525	02		75 70 207 000 2401	01							
70 56 135 700 2520	01		70 56 236 410 2501	01		71 11 021 504 2880	01		75 62 048 000 2415	02		75 70 220 000 2410	XX							
70 56 135 800 2140	04		70 56 248 300 2601	01		71 11 023 570 2425	01		75 62 049 010 2415	02		75 70 221 000 2410	XX							
70 56 137 000 2301	01		70 57 396 600 2420	01		71 11 218 260 2420	01		75 62 088 200 2750	01		75 70 222 000 2410	XX							
70 56 137 900 2501	22		70 58 022 900 2415	01		71 12 019 474 2725	05		75 62 377 000 2401	04		75 70 223 000 2410	XX							
70 56 144 800 2605	01		70 58 047 800 2501	01		71 12 421 404 2240	02		75 62 516 000 2701	01		75 71 279 000 2415	01							
70 56 161 600 2301	01		70 58 049 300 2520	01		71 12 421 510 2240	01		75 62 531 000 2240	01		75 71 291 000 2401	XX							
70 56 161 700 2301	01		70 58 055 400 2401	04		71 18 012 174 2415	02		75 62 536 000 2240	01		75 71 292 000 2401	XX							
70 56 166 900 2520	01		70 58 055 900 2410	04		71 18 512 184 6110	02		75 62 626 000 2301	01		75 71 297 000 2401	XX							
70 56 167 200 2415	10		70 58 057 700 2701	01		71 19 317 231 2415	02		75 62 627 000 2301	01		75 71 298 000 2401	XX							
70 56 168 800 2401	01		70 58 058 000 2430	01		71 19 319 310 2415	02		75 62 628 000 2301	01		75 71 299 000 2401	XX							
70 56 171 100 2415	01		70 58 060 600 2501	04		71 23 013 210 2240	01		75 62 629 000 2301	01		75 71 746 000 2501	01							
70 56 171 200 2415	01		70 58 061 000 2520	08		71 23 021 150 2710	04		75 62 643 000 2201	01		75 71 793 000 2525	01							
70 56 171 300 2415	02		70 58 061 200 2520	08		71 23 032 137 2865	01		75 62 693 000 2401	08		75 72 101 000 2401	08							
70 56 171 400 2415	01		70 58 064 200 2240	01		71 23 032 176 2415	12		75 62 727 000 2605	01		75 72 505 000 2525	01							



1 Ersatzteilnummer - Part Number - Numeros de las piezas - Numéro des pièces - Numero del pezzo

2 Bildtafelnummer - Plate Number - Numeros de las laminas - Numéro des planches - Numero della tavola

3 Menge pro Antriebsgruppe - Quantity per powerunit - Cantidad por grupo - Quantité par groupe - Quantita per gruppo

			1			2			3			1			2			3		
77 01 007 190 2835	02	77 01 007 458 2830	01	77 03 001 038 2420	01	78 25 124 003 2880	01	79 02 000 537 2730	02											
77 01 007 206 2105	01	77 01 007 477 2830	01	77 03 001 038 2420	02	78 70 035 200 2701	01	79 02 000 537 2735	02											
77 01 007 239 2211	01	77 01 007 478 2830	01	77 03 001 038 2430	20	79 02 000 002 2005	01	79 02 000 539 2730	01											
77 01 007 240 2211	01	77 01 007 479 2830	01	77 03 001 038 3350	06	79 02 000 003 2010	01	79 02 000 539 2735	01											
77 01 007 241 2210	01	77 01 007 480 2830	01	77 03 001 038 6110	02	79 02 000 004 2405	01	79 02 000 541 2715	02											
77 01 007 246 2210	XX	77 01 007 481 2830	01	77 03 001 039 2701	02	79 02 000 005 2601	01	79 02 000 546 2530	02											
77 01 007 247 2210	XX	77 01 007 482 2830	01	77 03 001 041 2701	02	79 02 000 007 2605	01	79 02 000 547 2715	01											
77 01 007 248 2210	XX	77 01 007 483 2830	01	77 03 001 043 2420	02	79 02 000 008 2605	01	79 02 000 548 2715	01											
77 01 007 251 2315	01	77 01 007 484 2830	01	77 03 001 043 2701	01	79 02 000 009 2605	01	79 02 000 566 2530	01											
77 01 007 252 2315	01	77 01 007 485 2830	01	77 03 001 044 2420	05	79 02 000 010 2605	01	79 02 000 584 2615	02											
77 01 007 253 2315	01	77 01 007 486 2830	01	77 03 001 046 2880	01	79 02 000 011 2605	01	79 02 000 584 2865	02											
77 01 007 256 2210	02	77 01 007 487 2830	01	77 03 001 054 2240	02	79 02 000 012 2605	01	79 02 000 587 2530	01											
77 01 007 274 2210	01	77 01 007 488 2830	01	77 03 001 054 2240	03	79 02 000 026 2410	02	79 02 000 595 2530	08											
77 01 007 275 2210	01	77 01 007 622 2710	02	77 03 001 054 2425	04	79 02 000 027 2410	XX	79 02 000 598 3350	04											
77 01 007 276 2210	XX	77 01 007 623 2710	02	77 03 001 054 2520	02	79 02 000 074 2203	01	79 02 000 599 3350	02											
77 01 007 277 2210	XX	77 01 007 624 2615	01	77 03 001 055 2605	03	79 02 000 074 2212	01	79 02 000 599 6110	02											
77 01 007 278 2210	XX	77 01 007 625 2245	01	77 03 001 055 2880	02	79 02 000 195 2701	01	79 02 000 600 3350	06											
77 01 007 279 2210	XX	77 01 007 627 3350	02	77 03 001 059 2725	01	79 02 000 206 2210	03	79 02 000 602 2530	04											
77 01 007 280 2210	XX	77 01 007 627 3370	02	77 03 001 075 2725	02	79 02 000 207 2210	01	79 02 000 604 2750	01											
77 01 007 283 2210	01	77 01 007 628 3370	04	77 03 001 075 2730	01	79 02 000 214 2203	01	79 02 000 607 2530	04											
77 01 007 284 2210	01	77 01 007 629 3370	04	77 03 001 075 2880	02	79 02 000 214 2212	01	79 02 000 608 6110	02											
77 01 007 285 2210	01	77 01 007 630 3370	04	77 03 001 077 2710	02	79 02 000 354 2415	01	79 02 000 611 2530	04											
77 01 007 286 2210	01	77 01 007 631 3370	04	77 03 001 077 3350	04	79 02 000 357 2005	01	79 02 000 612 2530	08											
77 01 007 287 2201	01	77 01 007 632 3370	04	77 03 001 079 2315	02	79 02 000 358 2401	XX	79 02 000 613 3350	04											
77 01 007 287 2210	01	77 01 007 633 3370	04	77 03 001 079 2880	03	79 02 000 359 2401	XX	79 02 000 613 3350	06											
77 01 007 288 2212	01	77 01 007 634 3350	02	77 03 001 088 2710	01	79 02 000 361 2405	01	79 02 000 613 6110	02											
77 01 007 289 2203	01	77 01 007 635 3350	02	77 03 001 098 2725	04	79 02 000 362 2401	01	79 02 000 616 3310	01											
77 01 007 289 2212	01	77 01 007 636 3350	02	77 03 001 099 2425	03	79 02 000 364 2501	01	79 02 000 651 2701	01											
77 01 007 291 2212	01	77 01 007 637 3350	04	77 03 001 116 2830	01	79 02 000 365 2525	01	79 02 000 668 2301	01											
77 01 007 292 2212	01	77 01 007 638 3350	08	77 03 001 118 3350	08	79 02 000 382 2415	01	79 02 000 669 2301	01											
77 01 007 293 2212	01	77 01 007 639 3350	01	77 03 001 162 3350	04	79 02 000 496 3350	02	79 02 000 675 2730	01											
77 01 007 294 2212	01	77 01 007 641 6101	01	77 03 001 402 2820	03	79 02 000 497 2501	02	79 02 000 675 2735	01											
77 01 007 296 2211	01	77 01 007 735 2315	01	77 03 066 077 2710	02	79 02 000 505 3350	01	79 02 000 676 6110	03											
77 01 007 297 2210	03	77 01 007 929 2530	01	77 03 066 091 3350	01	79 02 000 507 2820	01	79 02 000 680 2425	01											
77 01 007 298 2210	01	77 01 007 930 2530	01	78 05 055 200 2865	01	79 02 000 508 2730	03	79 02 000 684 2425	02											
77 01 007 299 2210	03	77 03 001 018 2425	06	78 06 045 000 2401	06	79 02 000 508 2730	04	79 02 000 688 2880	01											
77 01 007 300 2210	01	77 03 001 018 2601	03	78 13 119 100 2701	01	79 02 000 508 2735	03	79 02 000 689 2880	01											
77 01 007 319 2201	01	77 03 001 020 2415	10	78 21 069 100 2301	02	79 02 000 508 2735	06	79 02 000 690 2880	01											
77 01 007 456 2830	01	77 03 001 022 2415	02	78 25 007 760 2830	01	79 02 000 509 6110	01	79 02 000 698 2425	02											
77 01 007 457 2830	01	77 03 001 037 2420	01	78 25 118 100 2835	01	79 02 000 517 6110	01	79 02 000 733 2210	02											







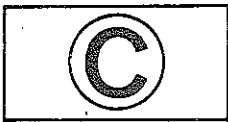

**130.50**

**130.50**



<p style="text-align: center;"><small>FRANÇAIS</small></p> <p>Tous les droits d'auteur sont réservés à la Société Commerciale de Moteurs - C.L.M. La reproduction ou la traduction même partielle du présent catalogue ainsi que l'utilisation du système de numérotage de référence des pièces de rechange sont interdites sans l'autorisation écrite et préalable de la Société Commerciale de Moteurs - C.L.M.</p> <p>© Société Commerciale de Moteurs - C.L.M. 1970</p>	<p style="text-align: center;"><small>DANSK</small></p> <p>Alle ophavsrettigheder tilhører Société Commerciale de Moteurs - C.L.M. Gengivelse eller oversættelse, også i uddrag, af dette katalog samt anvendelse af reservedelens nummereringssystem er ikke tilladt uden skriftlig tilladelse fra Société Commerciale de Moteurs - C.L.M.</p> <p>© Société Commerciale de Moteurs - C.L.M. 1970</p>	<p style="text-align: center;"><small>DEUTSCH</small></p> <p>Sämtliche Urheberrechte liegen bei der Société Commerciale de Moteurs - C.L.M. Nachdruck oder Übersetzung, selbst auszugsweise, des vorliegenden Kataloges sowie die Verwendung der Ersatzteilnummern und des Nummerierungssystems sind nicht gestattet ohne besondere schriftliche Genehmigung der Société Commerciale de Moteurs - C.L.M.</p> <p>© Société Commerciale de Moteurs - C.L.M. 1970</p>
<p style="text-align: center;"><small>ENGLISH</small></p> <p>All copyrights reserved by the Société Commerciale de Moteurs - C.L.M. Copying or translation, in part or in full of this catalogue or use of the spare part reference numerotation system is forbidden without the prior written authority of the Société Commerciale de Moteurs - C.L.M.</p> <p>© Société Commerciale de Moteurs - C.L.M. 1970</p>	<p style="text-align: center;"><small>ESPAÑOL</small></p> <p>La Société Commerciale de Moteurs - C.L.M. se reserva todos los derechos de autor. Queda prohibida la reproducción, o la traducción, incluso parcial, del presente catálogo, así como la utilización del sistema de numeración de referencia de las piezas de repuesto, sin la autorización por escrito de la Société Commerciale de Moteurs - C.L.M.</p> <p>© Société Commerciale de Moteurs - C.L.M. 1970</p>	<p style="text-align: center;"><small>ITALIANO</small></p> <p>Tutti i diritti d'autore sono riservati alla Société Commerciale de Moteurs - C.L.M. La riproduzione o la traduzione anche parziali del presente catalogo come pure l'utilizzazione del sistema di numerazione di riferimento delle parti di ricambio sono vietate senza previa autorizzazione scritta della Société Commerciale de Moteurs - C.L.M.</p> <p>© Société Commerciale de Moteurs - C.L.M. 1970</p>
<p style="text-align: center;"><small>NEDERLANDS</small></p> <p>Alle auteursrechten zijn voorbehouden aan de Société Commerciale de Moteurs - C.L.M. Reproducieren en/of vertalen, zelfs gedeeltelijk, van deze catalogus evenals het overnemen van indeling van dit boek en/of wijze van aanduiding der onderdelen is verboden zonder vooraf ontvangen schriftelijke goedkeuring van de Société Commerciale de Moteurs - C.L.M.</p> <p>© Société Commerciale de Moteurs - C.L.M. 1970</p>		<p style="text-align: center;"><small>SVENSKA</small></p> <p>Samtliga rättigheter förbehålls oinskränkta Société Commerciale de Moteurs - C.L.M. Eftertryck eller delvis översättning av denna reservdelskatalog samt användning av referenssystemet för numrerering av reservdelar är förbjudna utan skriftligt tillstånd från Société Commerciale de Moteurs - C.L.M.</p> <p>© Société Commerciale de Moteurs - C.L.M. 1970</p>

